



SENTRY™ Manual Pull Station Cover



Description

The SENTRY™ Station Cover is a rugged, poly-carbonate cover (UV stabilized) used to help protect manual pull stations from accidental or malicious false alarms, vandalism, dust, and weather. It is available in a variety of configurations to satisfy most application requirements. (See options below).

SENTRY™ Station Covers were designed specifically for compliance with the requirements of ADA (Americans with Disabilities Act: 28 CFR Part 36). This includes the ability to operate the station cover with just one hand, no more than 5 lbs of force and shall not require tight grasping, pinching or twisting of the wrist. It is uniquely designed to protrude less than 4 inches (100 mm) into halls, corridors and passageways, per 7/1/94 edition of ADA, part 36 paragraph 4.4.1.

Most surface mount manual pull stations are easily installed behind the SENTRY™ Station Cover. When operated, the SENTRY™ door can be opened **completely to a full 200°** providing unobstructed access to the manual pull station while allowing the door to be pushed all the way to the wall without damage.

An optional alarm module is available to deter malicious manual pull station false alarms in applications such as schools, hospitals, transit facilities and other areas of mass congregation. When this option is provided, the integral alarm module will emit a piercing siren tone upon opening the cover to access the station. In addition to deterring malicious pranksters, the siren will provide an audible indication of which SENTRY™ Station Cover has been activated.

Options

- Alarm module with piercing siren
- Weatherproof kit with gasket (NEMA 3R)
- Extender kit for surface mounting
- Backplate for rough surface mounting



Features

- Bottom hinge allows easy access for:
 - Alarm activation with one hand
 - Servicing station/alarm module
 - Replacing alarm module battery
- Indoor / Outdoor Applications
- Tough Poly-Carbonate
- 9 Volt Battery Included w/Alarm Module
- NEMA 3R rated w/Weatherproof Kit and Backplate
- Protrudes less than 4" per ADA requirements
- Raised lettering and Braille instructions on cover
- Optional ST-ALM01 Alarm Module produces a piercing (104dB +/-3 dB at 1 meter) tone to deter malicious false alarms
- A silencer key is provided with the Alarm Module to service the station



Signal Communications Corporation

Component Detail

Item	Qty	Description	Model
Backplate Kit			
1	1	Backplate	ST-BKP01
20	2	Screw, #10 Type A, 1" L Phillips Round Head with anchors	-
Extender Kit			
6	1	Extender	ST-XTR01
5	2	Conduit Block Plate	-
8	1	Compression Plate	-
21	4	Screw, #10 Type A, 4" L Phillips Round Head with anchors	-
Weatherproof Kit			
4	2	Conduit Gasket	ST-WPK01
2	1	Gasket, Flat	-
Front Cover Kit			
7	1	Frame	ST-FRC01
9	1	Front Cover	-
-	4	Screw, #10 Type A, 1-3/4" L Phillips Round Head with anchors (not shown)	-
Alarm Module Kit			
15	1	Alarm Module; 9Volt Battery included	ST-ALM01
10	1	Silencer Key	-
22	2	Screw, 6-32 x 3/8" L Phillips Pan Head	-
3	1	Surface Mount Pull Station (sold separately)	-

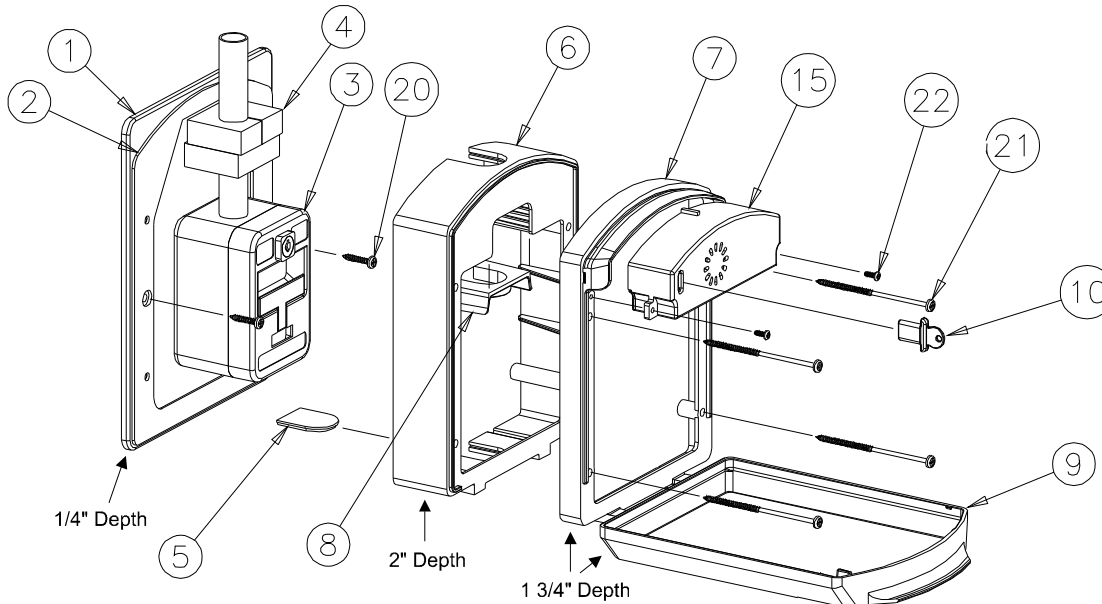

- Notes:
1. The SENTRY™ is supplied with wall anchors for installation on standard wallboard. For other types of walls, the necessary wall anchors must be provided by the installer.
 2. The SENTRY™ can be used to cover pull stations with maximum dimensions 5.5"W x 6"H x 1.6"D without the optional Extender Kit, 5.5"W x 6"D x 3.6"D with the extender.
 3. Where used, the optional Alarm Module should be tested periodically to verify the operation of the 9V battery.

Ordering information

Model	Description
ST-FRC01	Front Cover Kit

Options:

ST-ALM01	Alarm Module Kit
ST-WPK01	Weatherproof Kit
ST-BKP01	Backplate Kit
ST-XTR01	Extender Kit



Signal Communications Corporation