

### Features

**Electromagnetic door holders with models available for:**

- Flush wall mount for low profile applications
- Semi-flush wall mount for shallow box applications
- Surface wall mount
- Floor mount, single or double door

**Low current, multi-voltage design reduces power supply and battery demands:**

- Operates with 24 VDC, 24 VAC, or 120 VAC
- Current requirement is 15 mA at rated voltage (per magnet for double door floor mount)

**Internal full wave rectifier allows AC or DC operation and provides switching transient suppression**

**Low residual magnetism allows easy door release for compatibility with low pressure door closers**

**Quick and easy installation:**

- Self-adjusting swivel catch plate has two pivot points to adjust to door alignment changes
- Adhesive mounting templates assure alignment

**Holding force is 25 lbs minimum**

**UL listed to Standard 228**

**Optional accessories:**

- Extension rods of 1" or 3"
- Back plate for reinforced door mounting

### Description

Door holders are normally energized to provide door holding with a minimum force of 25 lbs. In the event of a fire emergency, the fire alarm control panel or other compatible control means will release the magnet allowing the door to close to prevent the spread of smoke. Doors may be manually closed or opened when the door holder is energized.

\* These products have been approved by the California State Fire Marshal (CSFM) pursuant to Section 13144.1 of the California Health and Safety Code. See CSFM Listing 3550-0026:232 for allowable values and/or conditions concerning material presented in this document. It is subject to re-examination, revision, and possible cancellation. ULC listed models are designated with a "C" suffix such as 2088-9607C, refer to page 2 for model availability. This product was not approved by FM or MEA (NYC) as of document revision date. Additional listings may be applicable, contact Simplex for the latest status.

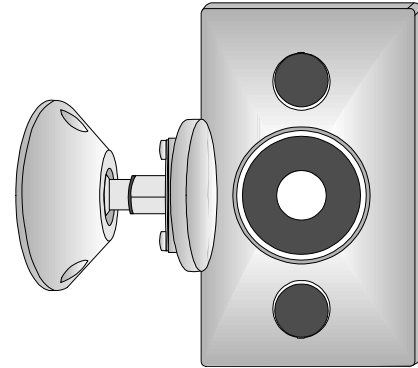

Semi-Flush Wall Mount Door Holder Magnet and Catch Plate (shown with screw hole caps in place)

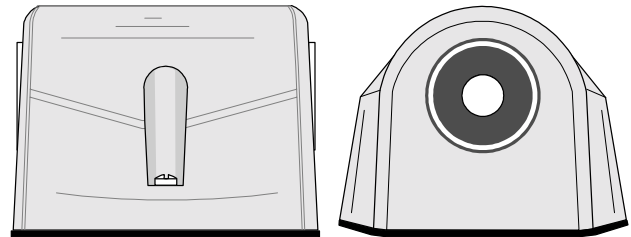

Floor Mount Side and Front View (Double door model shown)

### Specifications

#### Mechanical Specifications

Material	Durable die-cast metal
Finish	Double chrome plated, decorative surfaces are textured
Wiring Connections	Three position terminal block with provisions for in/out wiring (common, low voltage, high voltage)
Ground Connection	18 AWG wire lead, 9" minimum

#### Electrical Specifications

Nominal Input	Current	Voltage Range	Terminals
24 VDC	15 mA @ nominal	20.4 to 32	C & L
24 VAC			
120 VAC		102 to 132	C & H

## Product Selection

### Wall Mounted Door Holders, Voltage Selectable as 24 VDC, 24 VAC, or 120 VAC

Model*	Description	Electrical Box Requirement
2088-9607	Flush mount, includes magnet, catch plate, cover, and 3" (76 mm) chrome extension rod	Single gang box, 2 1/2" deep minimum (supplied by others)
2088-9608	Semi-flush mount, includes semi-flush magnet and cover assembly, catch plate, and screw hole caps	Single gang box, 2" deep minimum (supplied by others)
2088-9609	Surface mount, includes semi-flush magnet and cover assembly, catch plate, and matching electrical box	Surface mount box is supplied with door holder, dimensions: 4 5/8" H x 2 3/4" W x 2 1/8" D (117 mm x 70 mm x 54 mm)

### Floor Mounted Door Holders, Voltage Selectable as 24 VDC, 24 VAC, or 120 VAC

Model	Description	Electrical Box Requirement
2088-9610**	Floor mount for single door	Separate box is not required, wiring enters floor mount housing via bottom mounting plate
2088-9611**	Floor mount for double door	

### Optional Door Holder Accessories

Model	Description
2088-9680	Back plate for reinforcing catch plate, mounts on opposite side of door, recommended for hollow doors
2088-9681	Chrome catch plate extender rod, 1" (25.4 mm) long
2088-9682	Chrome catch plate extender rod, 3" (76 mm) long (supplied with 2088-9607 and floor mount models)

\* Add "C" suffix for ULC listed models (such as 2088-9607C).

\*\* Note: ULC listing in process for these models as of document revision date.

## 2088-9608, Semi-Flush Mount and 2088-9609, Surface Mount Magnet Dimensions

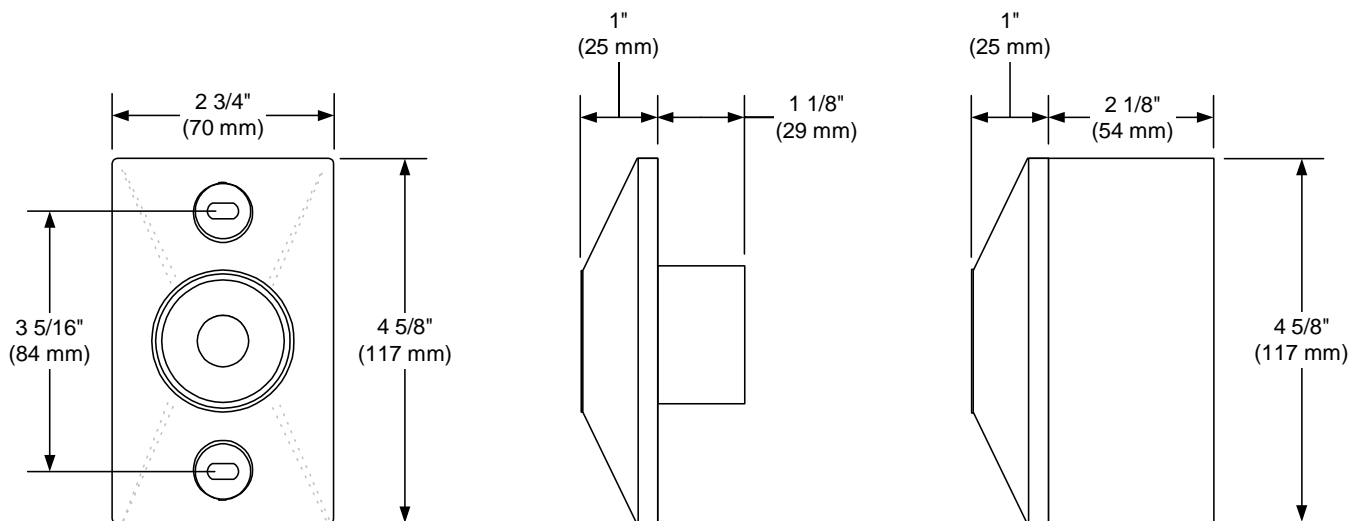

Semi-Flush and Surface Mount Front View

Semi-Flush Side View

Surface Mount Side View  
(conduit entries are provided on top, bottom, and back of box)

**2088-9607 Flush Mount Magnet Dimensions**

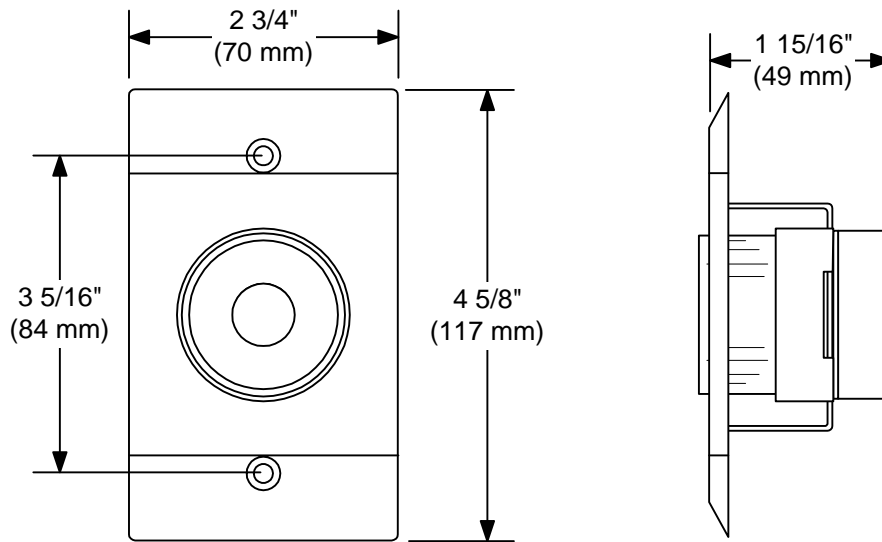

Flush Mount Front View

Flush Mount Side View

**Catch Plate Dimensions (supplied with each magnet assembly)**

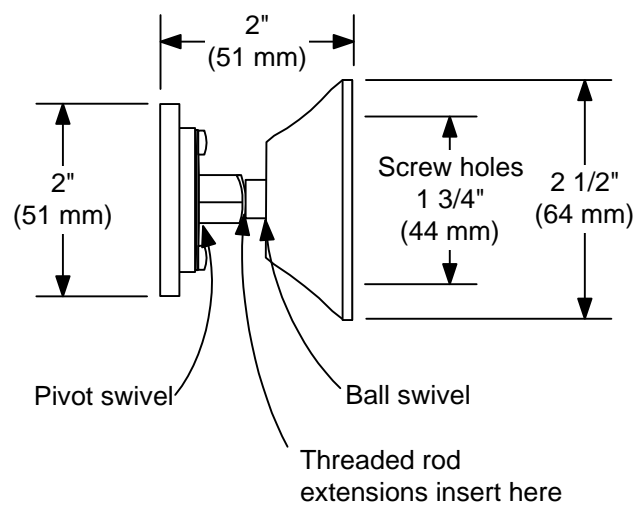

## Floor Mount Model Dimensions

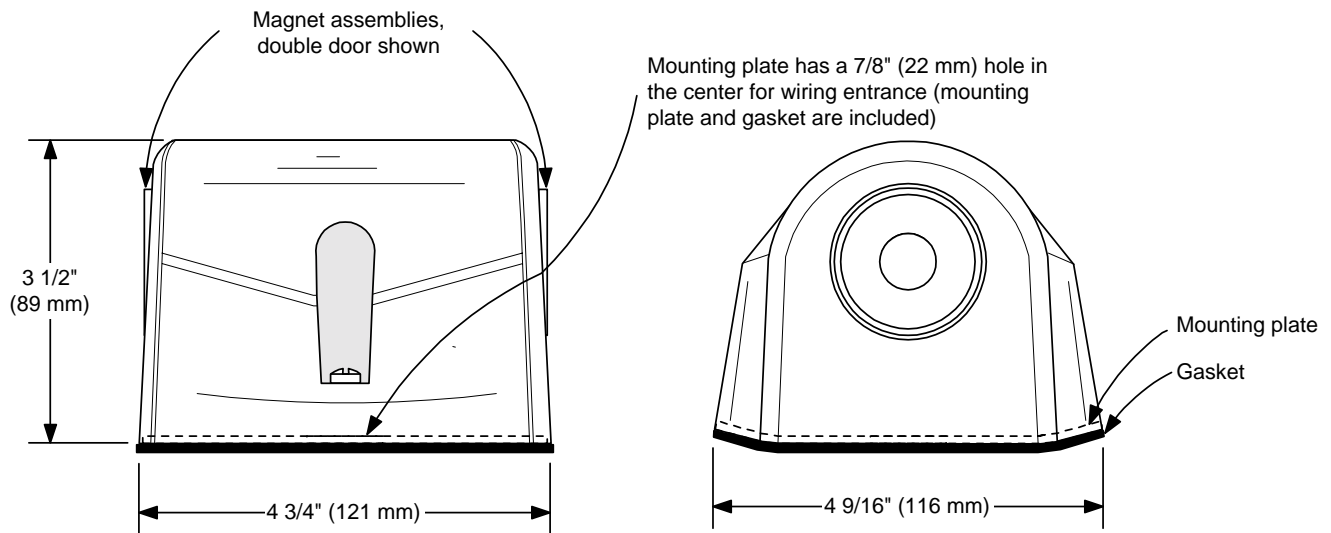

## 2088-9680 Optional Back Plate

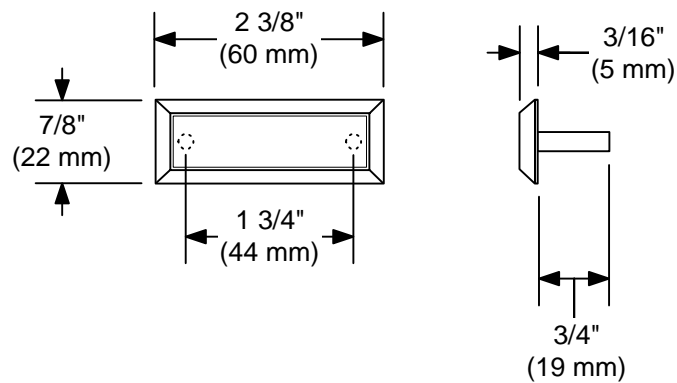

Simplex and the Simplex logo are registered trademarks of Simplex Time Recorder Co. in the U.S. and/or other countries.



S2088-0013-2 5/00

Westminster, Massachusetts 01441-0001 USA  
visit us on the world wide web at [www.simplexnet.com](http://www.simplexnet.com)

All specifications and other information shown were current as of printing and are subject to change without notice.