

# Intelligent Detection Devices

## Intelligent *FirePrint*<sup>™</sup> Detector

[For use with FireFinder<sup>®</sup> XLS and MXL<sup>®</sup> Panels]

Model FP-11

### ARCHITECT AND ENGINEER SPECIFICATIONS

- Multi-criteria fire detection
- Sophisticated 'detector intelligence'
- Remote-sensitivity-measurement capability
- Easily programmed to match specific hazard profiles from the fire-alarm control panel (FACP)
- *FirePrint*<sup>™</sup> technology to distinguish between deceptive phenomena and an actual fire
- *Pre-Alarm* reporting based upon fire profile selected
- Field-cleanable chamber with replaceable chamber parts
- System-logic activation based upon any of three (3) inputs from the detector (smoke, heat or neural network)
- Supports software-based, automatic environmental compensation
  - EnviroLINK
- Compatible with field programmer / tester
  - Model DPU / FPI-32 Upgrade Kit
- Backward compatible with older MXL systems
  - Rev. 2 and above
- Optional fully programmable relay base, audible base and duct housing



- Multi-color, detector-status light-emitting diode (LED)
- Two-wire operation
- <sup>®</sup>UL and <sup>®</sup>ULC Listed; FM, CSFM & NYCFD Approved

### Product Overview

The Intelligent Fire Detector (Model FP-11) is a highly evolved detection system that provides a very sophisticated level of fire protection, along with superior immunity to nuisance-alarms.

Model FP-11 utilizes highly developed detection technology that allows the detector to distinguish non-threatening deceptive phenomena (i.e. – cigarette smoke) from actual fire hazards, while optimizing detection for the area of its intended zone. Model FP-11 uses state-of-the-art microprocessor circuitry with error check; detector self-diagnostics, and supervision programs.

Model FP-11 is compatible with the Siemens – Fire Safety Model FPI-32 upgrade kit or Siemens' field-programmer / tester, Model DPU / FPI-32, which is a compact, portable and menu-driven accessory for efficiently programming and testing detectors electronically.

The upgrade kit (Models DPU or FPI-32) eliminates the need for cumbersome, unreliable mechanical programming methods, as well as reduces installation and service costs by electronically programming and testing the detector prior to installation.

### Specifications

Model FP-11 is a plug-in, two-wire and multi-sensor detector with photoelectric and thermal inputs that is compatible with the FireFinder XLS and MXL family of FACPs. Each detector consists of a dust-resistant, field-cleanable photo chamber; a solid-state, non-mechanical thermal sensor, and microprocessor-based electronics with a low-profile plastic cover and base.

Model FP-11 utilizes state-of-the-art ASIC and surface-mount technology for maximum reliability. Every Model FP-11 fire detector is shipped with a protective dust cover. Model FP-11 fire detector utilizes an infrared light-emitting diode (IRLED), and light-sensing photodiode.

Intelligent *FirePrint*<sup>™</sup> Detector **6175**

## Specifications — (continued)

Under normal conditions, light transmitted by the LED is directed away from the photodiode and scattered through the smoke chamber in a controlled pattern. The smoke chamber is designed to manage light dissipation and extraneous reflections from dust particles or other non-smoke airborne contaminants in such a way as to maintain stable, consistent detector operation. When smoke enters the detector chamber, light emitted from the IRLED is scattered by the smoke particles, and is received by the photodiode.

Model FP-11 also utilizes a modern, accurate and shock-resistant thermistor to sense temperature changes. The 'on-board' *FirePrint* technology allows the detector to gather smoke and thermal data, analyzing this data in the detector's 'neural network.' By comparing data received with the common characteristics of fires, or fire fingerprints, Model FP-11 can compare these 'fire prints' to those of deceptive phenomena that cause other detectors to go into *Alarm* mode.

This advanced *FirePrint* technology allows Model FP-11 to accurately determine a true fire hazard from non-threatening, deceptive phenomena — without the need to use alarm-delaying verification and confirmation techniques; thus decreasing the probability of losses in infrastructure from an actual fire.

Model FP-11 provides the highest level of detector intelligence available today with a detector / control-panel link that allows the user to program the detector for the specific hazard profile.

Detectors are optimized by selecting one (1) of the following applications:

- Office / Retail
- Lobby
- Computer room
- Dormitory
- Healthcare facility
- Parking garage
- Utility / transformer room
- Hostile environment
- Precious storage
- Air duct
- Warehouse / light manufacturing

Once programmed, the software does the rest — no guessing on detector sensitivities or alarm verification — the FACP programs Model FP-11 for the protected area without any confirmation delays.

Once optimized for the hazards in the protected area, Model FP-11 provides the utmost means in detection. Should the operator or installer forget to program the detector, Model FP-11 will revert to a default setting that, in turn, allows operation as a standard photoelectric or photothermal detector.

The *FirePrint* technology for Model FP-11 monitors input from the photo chamber and the thermal sensor, evaluating this information with sophisticated mathematical formulas or algorithms, and compares data transfer to this input to the characteristics of both threatening fires and deceptive phenomena that would deceive any ordinary detector.

This technology was developed over years of research and reviewing the results of over 20 years of fire-test data in one of the world's most advanced fire research centers. The results of this research are the mathematical models that form the algorithms used in *FirePrint*. No other fire detector has this level of intelligence or this amount of research and development supporting its design.

The software of the microprocessor can identify and disregard false input caused by radio frequency (RFI) and electromagnetic (EMI) interference, and validates all *Trouble* conditions before annunciating or reporting to the control panel. The microprocessor for Model FP-11 uses an integral electronically erasable programmable read-only memory (EEPROM) to store the detector's address and other critical operating parameters, which include the assigned program values for *Alarm* and *Trouble*—command thresholds.

Communications within the detector; between Model FP-11 and the FACP, or with the field programmer / tester (Model DPU / FPI-32), are supervised and safeguarded against disruption by reliable, microprocessor-based error checking routines. Additionally, the microprocessor supervises all EEPROM memory locations and provides a high degree of EEPROM failure fault tolerance.

Model FP-11 determines its operating status (*Normal*, *Alarm*, or *Trouble* modes) based upon the difference between the alarm-threshold values stored in the detector's memory and the detector's latest analog measurement. The detector then communicates changes in its status to the FACP.

In addition, the FACP will sample the value of the analog signal for Model FP-11 over a period of time, in order to determine if those values indicate excessive buildup in the photo chamber. In the event of excessive buildup, the FACP will accurately indicate which detector shall require maintenance.

Model FP-11 is listed as a self-testing device. The LED for Model FP-11 flashes **green** every four (4) seconds, indicating communication with the FACP, and that it has passed its self-test. Should the detector sense a fault or failure within its systems, the LED will flash **amber**, and the detector will transmit that data to the FACP. A quick visual inspection is sufficient to indicate the condition of the detector at any time.

## Specifications — (continued)

If more detailed information is required, a printed report can be provided from the FACP, indicating the status and settings assigned to each detector.

When Model FP-11 activates into *Alarm* mode, the detector will flash **amber**, and will transmit that data to the FACP. When the FACP confirms the condition of the detector, the FACP will instruct Model FP-11 to flash **red** – and continue to flash **red** – until the system is reset manually at the FACP. At that same time, any user-defined system alarm functions programmed into the system are activated. Each Model FP-11 detector can operate one (1) remote alarm indicator; one (1) auxiliary relay, or one (1) audible base.

Detector sensitivity, calibration and identification are dynamically supervised by the FACP. Detector sensitivity and *pre-Alarm* levels are a function of the application chosen at the FACP, and are controlled by the panel. If an alternate, *non-FirePrint* mode is selected, then the sensitivity can be changed from the FACP.

The Program / Test unit (Model DPU or FPI-32) upgrade kit is used to program and verify the detector's address. The technician selects the accessory's program mode to enter the desired address. Consequently, the programmer unit (Model DPU or FPI-32) will automatically set and verify the address, and tests the detector. Model DPU / FPI-32 also allows the user to change the device ID from that of a Model FP-11 detector to an older detector ID (such as: ILP-1, ILPT-1, ILP-2, ID-60P or ID-60PT) to allow for easy replacement of older detectors without the need of reprogramming the FACP.

The FPI-32 upgrade kit operates on AC power or rechargeable batteries, providing flexibility and convenience in programming and testing equipment from almost any location. When in 'test' mode, Model DPU or FPI-32 upgrade kit will perform a series of diagnostic tests without altering the address or other stored data, allowing technicians to determine if the detector is operating properly.

Model FP-11 may be installed on the same initiating circuit with Models IL or ID series detectors (Photoelectric, thermal, or ionization); Model MSI-series manual stations; Model TRI-series interfaces; Model ICP output-control devices, or Model CZM series of addressable, conventional-zone modules.

All Model FP-11 detectors can be cleaned in the field – when required – by simply removing the detector cover and unsnapping the photo chamber. There is also the option of cleaning the interior of the detector with a clean, soft cloth or brush, or replacing the labyrinth and bug screen included in the detector maintenance kit, Model DMK-11.

Model FP-11 uses the low-profile, surface-mounting base, Model DB-11. This base mounts on a 4-inch (10.2 cm.) octagon, square, or a single-gang electrical box. The base utilizes screw-clamp contacts for electrical connections and self-wiping contacts for increased reliability.

The base can be used with the optional Model LK-11 detector locking kit, which contains 50 detector locks, as well as an installation tool, thus preventing unauthorized removal of the detector head. Model DB-11 has integral, decorative plugs to cover the outer mounting screw holes.

Model FP-11 is electrically compatible with existing MXL-detector accessories, including relays, remote lamps, duct housings and audible bases. To use existing Model DB-3S base or audible base, Model FP-11 requires a base adapter (Model DB-ADPT).

## Application Data

Installation of the Model FP-11 series of fire detectors requires a (2) two-wire circuit of 18 American Wire Gauge (AWG), minimum, thermoplastic fixture wire enclosed in conduit, or 18 AWG (American Wire Gauge) limited-energy, shielded-cable without conduit, if permitted by local codes. Field wiring should conform to local and national electric codes and the control panel wiring specifications.

'T-tapping' is permitted only for Style 4 (Class B) wiring.

Model FP-11 fire detectors can be applied within the maximum 30-foot center spacing (900 sq. ft. areas), as referenced in NFPA 72. This applications guideline is based upon ideal conditions – specifically – smooth ceiling surfaces, minimal air movement, and no physical obstructions between potential fire sources and the detector. Do not mount detectors in close proximity to ventilation or heating and air-conditioning outlets.

Exposed joints or beamed ceilings may also affect safe spacing limitations for detectors. Should questions arise regarding detector placement, observe National Fire Protection Association (NFPA) 72 guidelines.

## Technical Data

### Environmental

|                    |                              |
|--------------------|------------------------------|
| Temperature:       | 32°F (0°C) to 100°F (38°C)   |
| Humidity:          | Up to 93% RH, non-condensing |
| Air Pressure:      | No effect                    |
| Alarm Temperature: | 135°F (57°C)                 |

### Electrical

|                      |                  |
|----------------------|------------------|
| Voltage:             | 16 – 27 VDC      |
| Ripple:              | 3V, peak-to-peak |
| Supervisory Current: | 110µA max        |
| Alarm Current:       | 33 – 50mA        |

## Dimensions

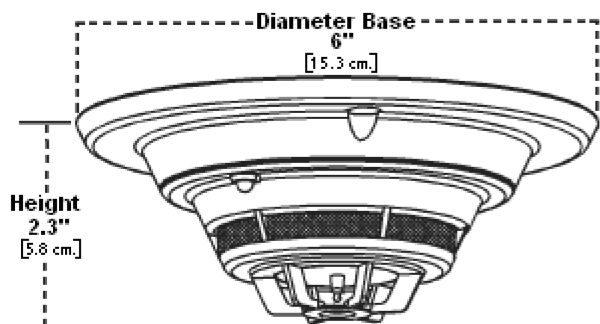

## Details for Ordering

| Model      | Part Number   | Description  |
|------------|---------------|--|
| FP-11      | 500-095112    | Addressable <i>FirePrint</i> ™ Detector  |
| DB-11      | 500-094151    | Detector Mounting Base<br>For Series 11 Intelligent Detectors  |
| ADBX-11    | 500-096181    | Audible Base   |
| DB-11E     | 500-094151E   | Detector Base (Small)  |
| DB-ADPT    | 500-094187    | Base Adapter to Model DB-3S Base   |
| DB-X11RS   | 500-096125    | Relay Base for Model 11-series<br>Intelligent Detectors  |
| DMK-11     | 500-695338    | Model 11-series Maintenance Kit<br>(replacement labyrinth and bug screen)  |
| FDBZ492    | S54319-B22-A1 | <b>Air-Duct Housing</b><br>A two-wire addressable or conventional duct detector (without relays) designed for direct use on heating, ventilating and air-conditioning (HVAC) air-duct systems. When equipped, the air-duct detector housing will signal the presence of smoke being carried through the duct system. |
|            |               | <b>Air-Duct Housing</b><br>A two-wire addressable duct detector (with relays) designed for direct use to HVAC air-duct systems. This part has a programmable relay base, and when equipped, the addressable air-duct detector housing will signal the presence of smoke being carried through the duct system.       |
| FDBZ492-HR | S54319-B23-A1 |  |
| LK-11      | 500-695350    | Base Locking Kit for Series 11 Detectors   |
| RLI-1      | 500-390673    | <b>Remote Alarm Indicator</b><br>4" Octagon Box Mount, <b>Red</b>  |
| RLI-2      | 500-390674    | <b>Remote Alarm Indicator</b><br>Single-Gang Mount, <b>Red</b>   |

### In Canada, please order:

| Model     | Part Number | Description   |
|-----------|-------------|---|
| FP-11C    | 500-095112C | 135°F Fixed Temperature, Plug-In Detector Addressable <i>FirePrint</i> ™ Detector [UL Listed] |
| DB-11C    | 500-095687  | Detector Mounting Base<br>(for Model 11-series Intelligent Detectors)<br>[UL Listed]          |
| DB-X11RSC | 500-093125C | Relay Base for Model 11-series<br>Intelligent Detectors [UL Listed]                           |
| ADBX-11C  | 500-096181C | Audible Base for Model 11-series<br>Intelligent Detectors [UL Listed]                         |

**Notice:** This marketing data sheet is not intended to be used for system design or installation purposes. For the most up-to-date information, refer to each product's installation instructions.