

Features

Designed specifically for protection of fire alarm circuits including:

- DC power (200 mA maximum)
- Data communications
- Local energy city circuit connections
- Rugged epoxy encapsulated package
- Refer to page 2 for application details

Multiple stages of protection include:

- Line-to-Line protection and Line-to-Earth protection

Listings Reference:

- Listed as an Overvoltage Protector to UL 864, *Control Units and Accessories for Fire Alarm Systems*
- Listed as an Overvoltage Protector to ULC-S527, *Control Units for Fire Alarm Systems*
- Listed as an Isolated Loop Circuit Protector to UL 497B, *Protectors for Data Communications and Fire Alarm Circuits*
- Compatible with the requirements of the National Electrical Code (NFPA 70)

Description

Circuit Protection. Electrical transients caused by lightning or by disturbances on high voltage power lines can cause damage to low voltage fire alarm circuits. Proper application of 2081-9044 Overvoltage Protectors can minimize the energy from those electrical transients to a level that can be safely handled by the circuits requiring protection. This protection is most effective when placed at the locations where the circuits leave and enter buildings.

The 2081-9044 Overvoltage Protector provides multiple stages of protection against electrical transients. The small package size allows it to be easily mounted at the location that achieves maximum protection.

External Wiring Requirements

Fire alarm system wiring that is run external to the building and is protected by 2081-9044 Overvoltage Protectors shall be installed in accordance with the individual system component’s installation instructions including properly grounded, twisted and shielded wire pairs, and observance of the following precautions.

Location. To ensure optimized protection, the 2081-9044 Overvoltage Protector shall be located as close as possible to the point at which the circuits leave or enter the buildings and installed in dedicated metallic electrical boxes.

Wiring distance is limited to one contiguous property. The total maximum wire length is determined by the individual application’s allowable limit as specified with overvoltage protectors, but must not exceed 3270 ft (1 km).

The grounding conductor shall be 12 AWG with a maximum length of 28 ft (8.5 m), run in as straight a line as possible and connected to the building grounding electrode system per NFPA 70, the *National Electrical Code*.

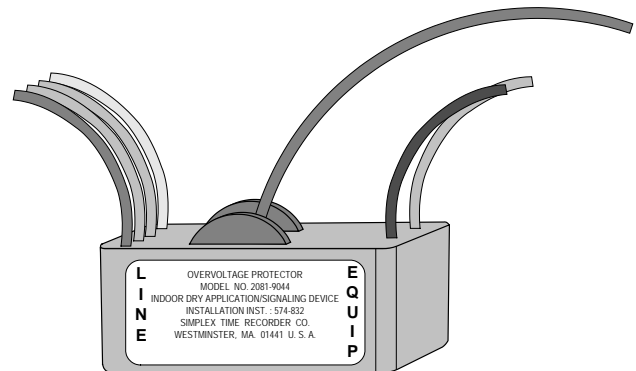

2081-9044 Overvoltage Protector

Operating Specifications

Line-to-Line Voltage Rating	Continuous: 38 VDC, 28 VAC RMS Clamping: 47 V typical
Line-to-Earth Voltage Rating	Continuous: 45 VDC, 35 VAC RMS Clamping: 56 V typical
Shield-to-Earth Voltage Rating	Continuous: 48 VDC, 33 VAC RMS Clamping: 75 V typical
Line-to-Line Capacitance	0.006 µF typical
Continuous Current Rating	200 mA maximum
Series Resistance	3 Ω/line
Response Time	Line-to-Line <1 Nanosecond (10 ⁻⁹)
	Line-to-Earth <25 Nanosecond (10 ⁻⁹)
Maximum Current	Line-to-Line 2000 A (10 x 50 µsec pulse)
	Line-to-Earth 2000 A (8 x 20 µsec pulse)
	Shield-to-Earth 5000 A (10 x 50 µsec)

Mechanical Specifications

Dimensions	2 7/16" W x 1 3/8" D x 1 1/16" H (62 mm x 35 mm x 27 mm)
Package	Beige epoxy encapsulated
Electrical box requirement	4" (102 mm) square box, 2 1/8" (54 mm) minimum depth
Temperature Rating	32° F to 120° F (0° C to 49° C)
Humidity Rating	10-95% RH, at 30° C
Signal Leads	Color coded, 18 AWG (0.82 mm ²), 10" long (245 mm)
Ground Lead	Green, 14 AWG, 10" long (254 mm)
Installation Instructions	574-832

* This product has been approved by the California State Fire Marshal (CSFM) pursuant to Section 13144.1 of the California Health and Safety Code. See CSFM Listing 7300-0026:171 for allowable values and/or conditions concerning material presented in this document. This product was not FM or MEA (NYC) approved as of document revision date. Additional listings may be applicable; contact your local Simplex product supplier for the latest status. Listings and approvals under Simplex Time Recorder Co. are the property of Tyco Fire Protection Products.

2081-9044 Overvoltage Protector Application Reference

The 2081-9044 Overvoltage Protector is for fire alarm circuit use as listed below. These circuits may be standard or optionally available on the following Fire Alarm Control Panel Series: 4007ES, 4010, 4010ES, 4100ES, 4100U, 4020, 4100, and 4120. Applications listed for remote device output circuits include the applicable device model number below the description.

Compatible Fire Alarm Control Panel Circuits

Circuit Type	Wiring Distance and Requirements
IDNet Communications	Two, 2081-9044's, 2500 ft (762 m) maximum Four, 2081-9044's, 1500 ft (457 m) maximum
Monitor ZAM IDC; 4090-9101 and 4090-9106	1400 ft (428 m) maximum
Supervised IAM Zone; 4090-9001 and 4090-9051	400 ft (122 m) maximum
RUI/RUI+ Communications	Reduce maximum line distance by 1000 ft (305 m) for first two suppressors; each additional suppressor reduces distance by 500 ft (152 m)
Fire Alarm Network, Wired Communications	Maximum of two per node-to-node connection, no impact to total distance limit
IDNAC and TrueAlert SLCs	200 mA maximum current, 2500 ft (762 m) total length on branch with suppressor; 6 Ω of line resistance must be accounted for in voltage drop calculations; Maximum of two suppressors on a branch (Note: Do not mix with 2081-9028 Isolated Loop Circuit Protector (ILCP))
Phone/Audio risers	25 VRMS Audio only, limited to 200 mA
Local Energy City Circuit	3270 ft (1 km) maximum; (Note: For Reverse Polarity City Circuits, use 2081-9045; refer to data sheet S2081-0007)
N2 Communications (4010 Series Models Only)	Two, 2081-9044's, 2500 ft (762 m) maximum Four, 2081-9044's, 1500 ft (457 m) maximum
MAPNET II Communications	Two, 2081-9044's, 1500 ft (457 km) maximum Four, 2081-9044's, 500 ft (152 km) maximum
MAPNET II ZAM Power; 2190-9153 through 2190-9164	3270 ft (1 km) maximum, 200 mA maximum

General Precautions for All Circuit Types (subject to local codes)

Underground wiring must be in a wiring trough that is separate from commercial power distribution wiring.

Overhead wiring must be run on poles separate from those supporting any commercial power distribution wiring. Wiring shall be run in parallel with the commercial power distribution wiring and be separated by a minimum distance of either 100 ft (30 m) or the maximum span between any two adjacent poles of either the system's circuit or the commercial power distribution circuit.

Typical Connection Reference (refer to Installation Instructions 574-832 for additional information)

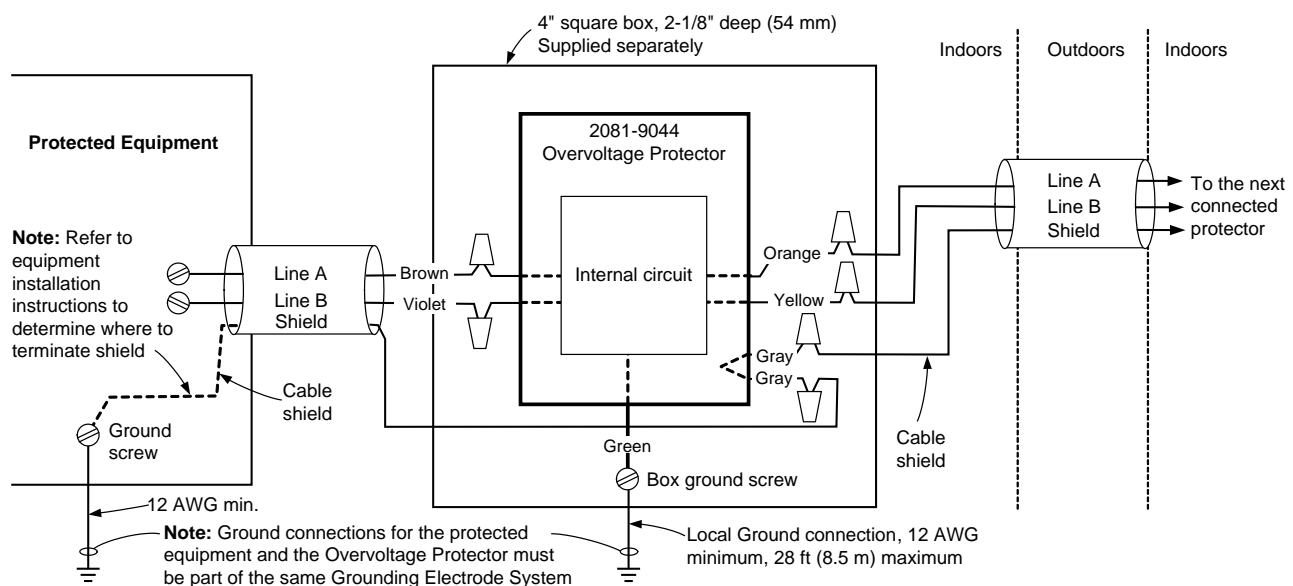

TYCO, SIMPLEX, and the product names listed in this material are marks and/or registered marks. Unauthorized use is strictly prohibited. NFPA 70 and National Electrical Code are registered trademarks of the National Fire Protection Association (NFPA).



Tyco Fire Protection Products • Westminster, MA • 01441-0001 • USA
www.simplex-fire.com

S2081-0016-4 12/2014

© 2014 Tyco Fire Protection Products. All rights reserved. All specifications and other information shown were current as of document revision date and are subject to change without notice.