

Features

Single or dual channel intrinsically safe, transformer isolated barrier modules:

- 2081-9062, Single channel
- 2081-9063, Dual channel

Meets requirements of National Electrical Code Articles 500-517 for Hazardous Locations:

- Classes I, II, & III
- Divisions 1 & 2
- Groups A, B, C, D, E, F, & G

Compatible with Simplex® intrinsically safe manual stations and simple apparatus:

- Refer to page 2 for compatible product details including compatible smoke detector model
- Product selection summary is detailed on page 7

Required accessories (ordered separately):

- 2975-9218, Red cabinet with solid door and lock
- 2081-9061, Module installation kit

Description

Simplex Intrinsically Safe Modules are for use with FM Approved Simplex control panels to make initiating device circuit wiring safe for use in locations where hazardous concentrations of flammable gases or other materials may exist. The intrinsically safe module is an isolated, power-limited barrier that limits the output current to a level below ignition for atmospheres defined by NEC Articles 500-517 for Classes I, II, & III, Divisions 1 & 2, Groups A, B, C, D, E, F, & G.

Installation Considerations. The installation of intrinsically safe modules requires strict adherence to product compatibility lists and must be in accordance with all product installation instructions and applicable codes and wiring practices.

Review all applicable references thoroughly before completing the intrinsically safe design.

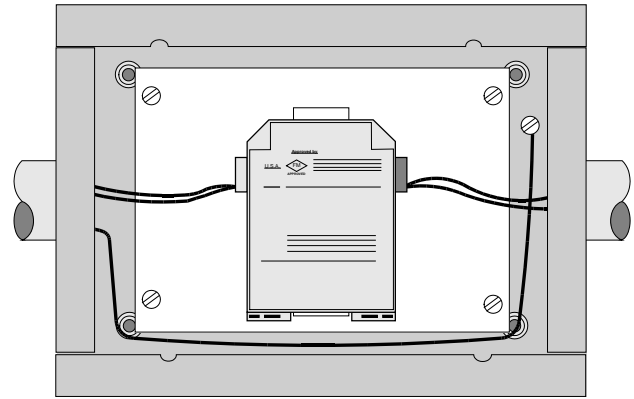

Intrinsically Safe Barrier Module Mounted in Cabinet (shown with cover removed, wiring and conduit shown for reference only)

Specifications

Barrier Modules 2081-9062 and 2081-9063**

Input Voltage (V _{in})	4 to 35 VDC	
Input Current (I _{in})	40 mA maximum, limited by module impedance	
Output Voltage (V _{out})	V _{in} < 23.7 V	V _{out} = V _{in} - (400 x I _{in}) - 0.7 V
	V _{in} > 23.7 V	V _{out} = V _{in} - (400 x I _{in})
Output Current	Transfer current ≤ 40 mA Short circuit current ≤ 65 mA	
Operating Temperature	32° F to 120° F (0° C to 49° C)	
Operating Humidity	Up to 85% RH maximum @ 86° F (30° C)	
Dimensions	4-1/2" H x 4-1/4" W (including terminal block) x 13/16" D (114 mm x 108 mm x 21 mm)	

2975-9218 Cabinet; Required, Ordered Separately

Dimensions	12" W x 8-3/8" H x 3-1/2" D (305 mm x 213 mm x 89 mm)
Color	Red

2081-9061 Installation Kit; Required, Ordered Separately

Contents	Bracket for barrier module mounting (35 mm DIN rail type), mounting hardware, control drawing, and required end-of-line resistors
----------	---

* Refer to page 2 for listing exceptions. This application is FM approved only. Contact your local Simplex product supplier for additional information. Listings and approvals under Simplex Time Recorder Co. are the property of Tyco Safety Products Westminster.

** Refer to page 7 for listing of approved entity parameters and allowable wiring distances.

Intrinsically Safe Barrier Module Compatibility

Simplex 2081-9062 and 2081-9063 Intrinsically Safe Modules report alarms as a current limited condition. FM Approval is for use with the **Simplex** fire alarm control panels and peripheral devices described in the following selection chart.

NOTE: Intrinsically Safe applications are NOT COMPATIBLE with Alarm Verification operation.

Compatibility Reference

Compatible Simplex Fire Alarm Control Panels and Modules

Model Series	Description
4004 and 4005	Class B IDCs, both standard and "high current"
4020	Class B IDCs
4100	Class B IDC module 4100-5004
4100U	Class B IDC module 4100-5005

Zone Adapter Modules (ZAMs)

Model	Description
2190-9155	Class B (surface cover); MAPNET II [®] communications only
2190-9156	Class B (flush cover); MAPNET II communications only
4090-9101	Class B, for use with compatible Simplex fire alarm control panels; MAPNET II or IDNet™ communications

Compatible Initiating Devices*

Manual Stations

Model Series	Description
2099-9767	Single Action Station
2099-9799	Double Action (Breakglass) Station

Simple Apparatus

Any device which does not store or generate more than 1.2 V, 100 mA, or 20 μ J (typically a dry contact heat detector or pushbutton switch)

Compatible Smoke Detector (NOTE: NOT FM APPROVED, but tested as compatible with IDCs listed)

Compatible IDCs	Description
4100-5004	Hochiki Intrinsically Safe Photoelectric Smoke Detector Model SLR-E-IS with Hochiki Intrinsically Safe
4100-5005	Detector Base Model YBN-R/4-IS ; NOTE: Five (5) maximum per circuit ; Available from Hochiki
4090-9101	America

* Although the above listed peripheral model numbers are FM Approved as Intrinsically Safe (except as noted), *these peripheral devices and any simple apparatus must be selected for proper fire protection compatibility with the dust content and corrosion potential of the atmosphere to be protected.*

Installation Requirements

1. All equipment **MUST** be installed in accordance with the National Electrical Code, NEC ANSI/NFPA 70 Article 504, and ANSI/ISA-RP 12.6-1987.
2. Cable and/or conduit from Non-Hazardous and Hazardous locations **MUST** enter the barrier enclosure from opposite sides and **MUST** be sealed per National Electrical Code, Article 504.
3. Intrinsically Safe circuits **MUST NOT** be installed in the same cable, conduit, or raceway with non-intrinsically safe circuits.
4. Intrinsically Safe circuits are for indoor applications only.
5. Maximum line resistance from the Fire Alarm panel to the last device in the Hazardous location is 10 Ω .
6. The 2975-9218 cabinet must be equipped with a safety ground per NEC Article 250-42. The grounding conductor must be 12 AWG (3.31 mm²) minimum (the barrier is not grounded).
7. For additional wiring information, reference the National Electrical Code, Articles 500 through 517 and **Simplex Control Drawing 842-070**.
8. Refer to page 7 for approved entity parameter information reference.

Installation Reference

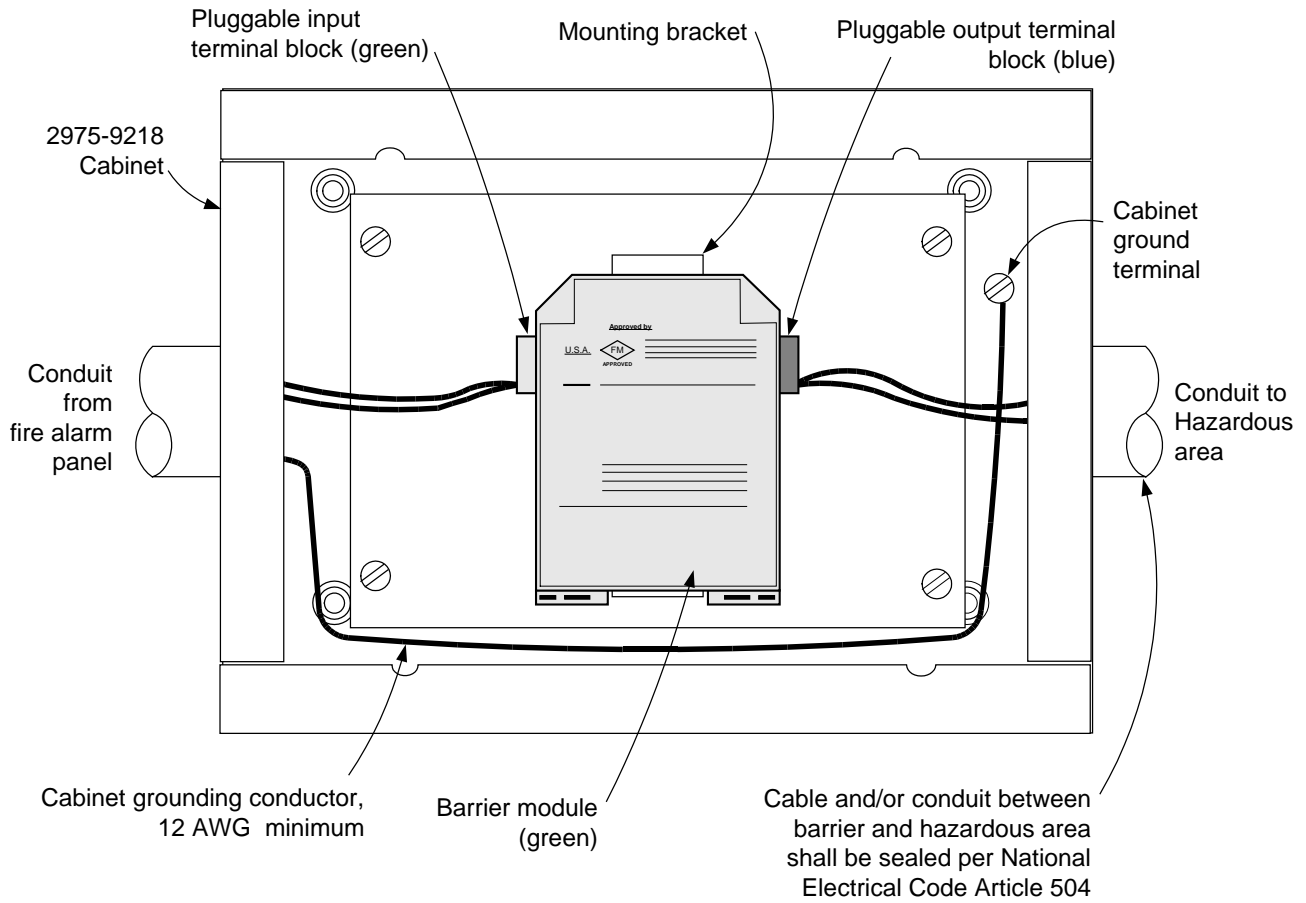

Wiring Diagram Reference

Diagram below is for reference only, refer to Control Diagram 842-070 for complete installation details.

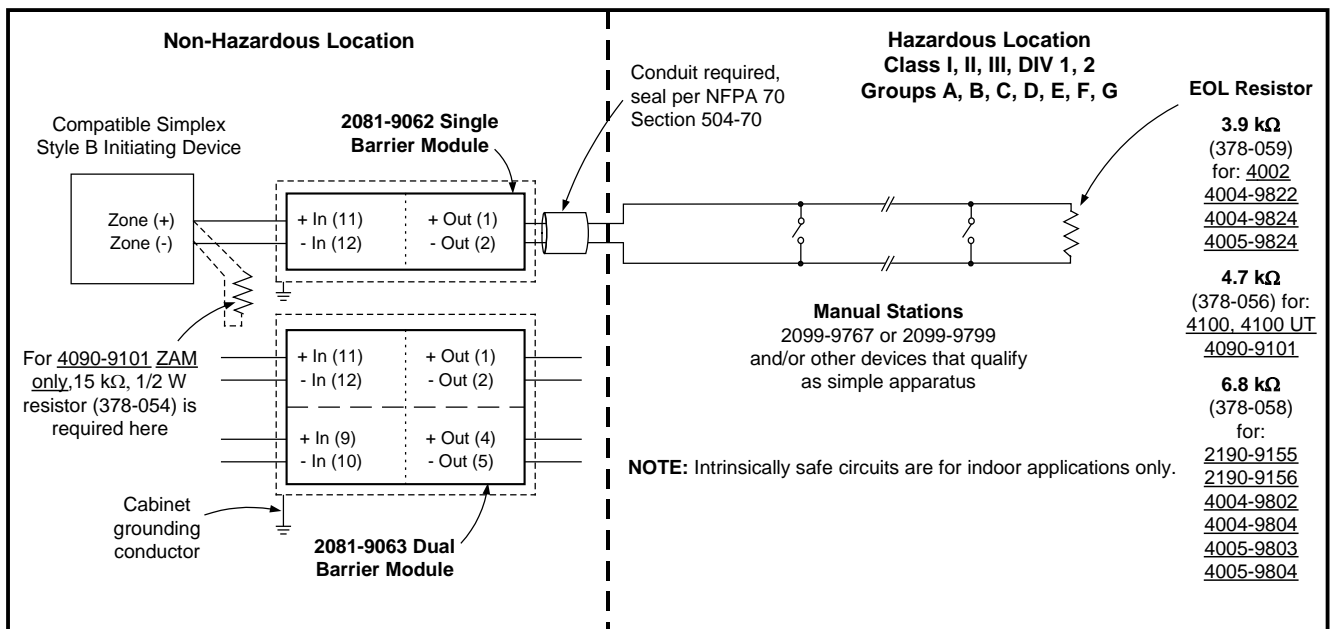

National Electrical Code Hazardous Location Classifications*

Class I Locations

Class I locations are those in which flammable gases or vapors are, or may be, present in the air in quantities sufficient to produce explosive or ignitable mixtures.

Class I, Division 1

A Class I, Division 1 location is a location:

1. In which ignitable concentrations of flammable gases or vapors can exist under normal operating conditions; or
2. In which ignitable concentrations of such gases or vapors may exist frequently because of repair or maintenance operations or because of leakage; or
3. In which breakdown or faulty operation of equipment or processes might release ignitable concentrations of flammable gases or vapors, and might also cause simultaneous failure of electric equipment.

Class II Locations

Class II locations are those that are hazardous because of the presence of combustible dust.

Class II, Division 1

A Class II, Division 1 location is a location:

1. In which combustible dust is in the air under normal operating conditions in quantities sufficient to produce explosive or ignitable mixtures; or
2. Where mechanical failure or abnormal operation of machinery or equipment might cause such explosive or ignitable mixtures to be produced, and might also provide a source of ignition through simultaneous failure of electric equipment, operation of protection devices, or from other causes; or
3. In which combustible dusts of an electrically conductive nature may be present in hazardous quantities.

Class III Locations

Class III locations are those that are hazardous because of the presence of easily ignitable fibers or flyings, but in which such fibers or flyings are not likely to be in suspension in the air in quantities sufficient to produce ignitable mixtures.

Class III Division 1

A Class III, Division 1 location is a location in which easily ignitable fibers or materials producing combustible flyings are handled, manufactured, or used.

General Note, Division 2 Categories

Equipment marked Division 1 is suitable for both Division 1 and Division 2 locations.

Group Definitions

Class I:

Group A. Atmospheres containing acetylene.

Group B. Atmospheres containing hydrogen, fuel and combustible process gases containing more than 30 percent hydrogen by volume, or gases or vapors of equivalent hazard such as butadiene, ethylene oxide, propylene oxide, and acrolein.

Group C. Atmospheres such as, ethyl ether, ethylene, or gases or vapors of equivalent hazard.

Group D. Atmospheres such as acetone, ammonia, benzene, butane, cyclopropane, ethanol, gasoline, hexane, methanol, methane, natural gas, naphtha, propane or gases, or vapors of equivalent hazard.

Class II:

Group E. Atmospheres containing combustible metal dusts, including aluminum, magnesium, and their commercial alloys, or other combustible dusts whose particle size, abrasiveness, and conductivity present similar hazards in the use of electrical equipment.

Group F. Atmospheres containing combustible carbonaceous dusts, including carbon black, charcoal, coal, or dusts that have been sensitized by other materials so that they present an explosion hazard.

Group G. Atmospheres containing combustible dusts not included in Group E or F, including flour, grain, wood, plastic, and chemicals.

Reference

For additional information concerning these hazardous location classifications, refer to NFPA 70, the *National Electrical Code*. (A publication of NFPA, the National Fire Protection Association.)

** Please note that the above information is summarized from NFPA 70, Article 500 and is presented for reference only. Refer to NFPA 70 for further information.*

Intrinsically Safe Manual Stations

Description

Single action stations require a firm downward pull to break the plastic rod visible below the pull lever and actuate a switch to sound the alarm. The front of the station is hinged and must be opened to reset the station and to replace the plastic rod.

Double action stations require that the hammer, hung on the front of the station, be lifted and thrown downward against the glass window, thus breaking it to expose the recessed pull lever. As with the single action station, a firm downward pull of the pull lever actuates and locks in the alarm switch.

Single action station reset. To reset the single action station, a key unlocks and opens the station which then permits the handle to return to its normal position when the station is relocked. If a break-rod is used, it must be replaced in order to complete the reset process.

Double action station reset. The double action station is reset in a similar manner except that the glass window must be replaced to restore operation.

Mounting Notes

1. For **surface mounting**, use a Simplex 2975-9178 red steel back box or a 2975-9022 aluminum back box. Do not substitute a box with a depth less than 2-3/16" (56 mm). Refer to drawing below.
2. For **semi-flush mounting**, use a standard single gang 2-1/2" (64 mm) deep switch box. **DO NOT RECESS BOX**, mount box flush or with 1/16" (2 mm) maximum protrusion. Refer to drawing on page 6.
3. For **flush mounting**, refer to drawing on page 6.
4. Wiring is 18 AWG minimum, 14 AWG maximum (0.82 mm², 2.08 mm²).



2099-9767 Intrinsically Safe Single Action Manual Station

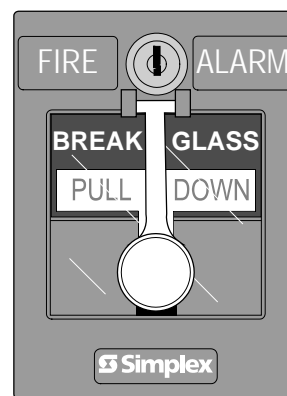

2099-9799 Intrinsically Safe Double Action Breakglass Manual Station

Surface Mounting Reference

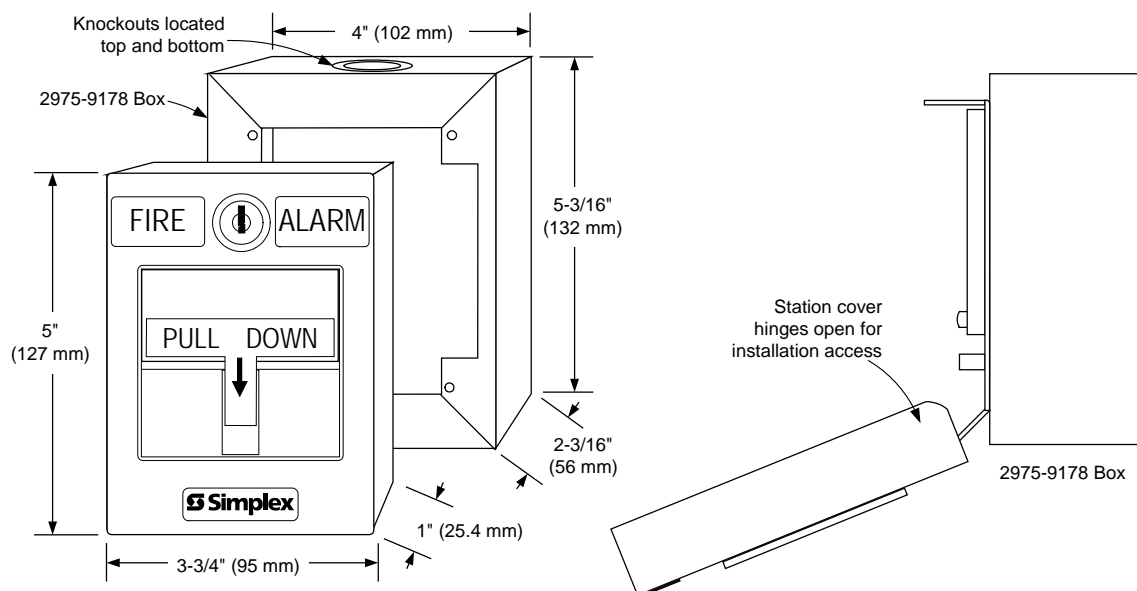

Intrinsically Safe Manual Station Semi-Flush Mounting

Single Gang Box Mount

Single gang box, 2-1/2" deep (64 mm), RACO #500 or equal (supplied by others)

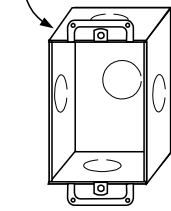

4" Square Box Mount

4" (102 mm) square box, 2-1/8" (54 mm) minimum depth, RACO #231 or equal (supplied by others)

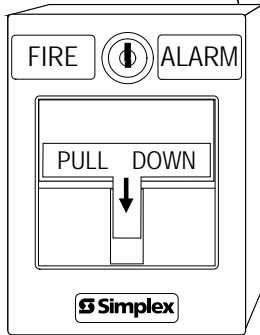
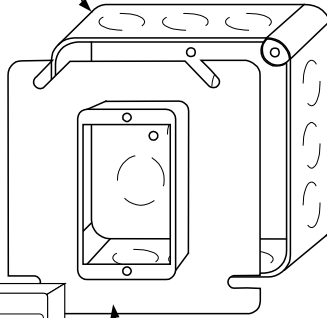

Single gang cover plate, 3/4" (19 mm) extension, RACO #773 or equal (supplied by others)

Mount flush or with 1/16" (2 mm) maximum extension
DO NOT RECESS

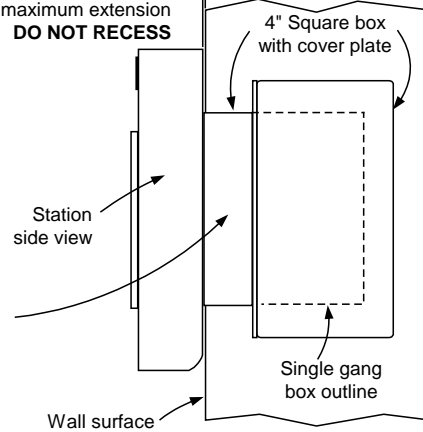

Semi-Flush Mount Side View

Intrinsically Safe Manual Station, Flush Mounting Information

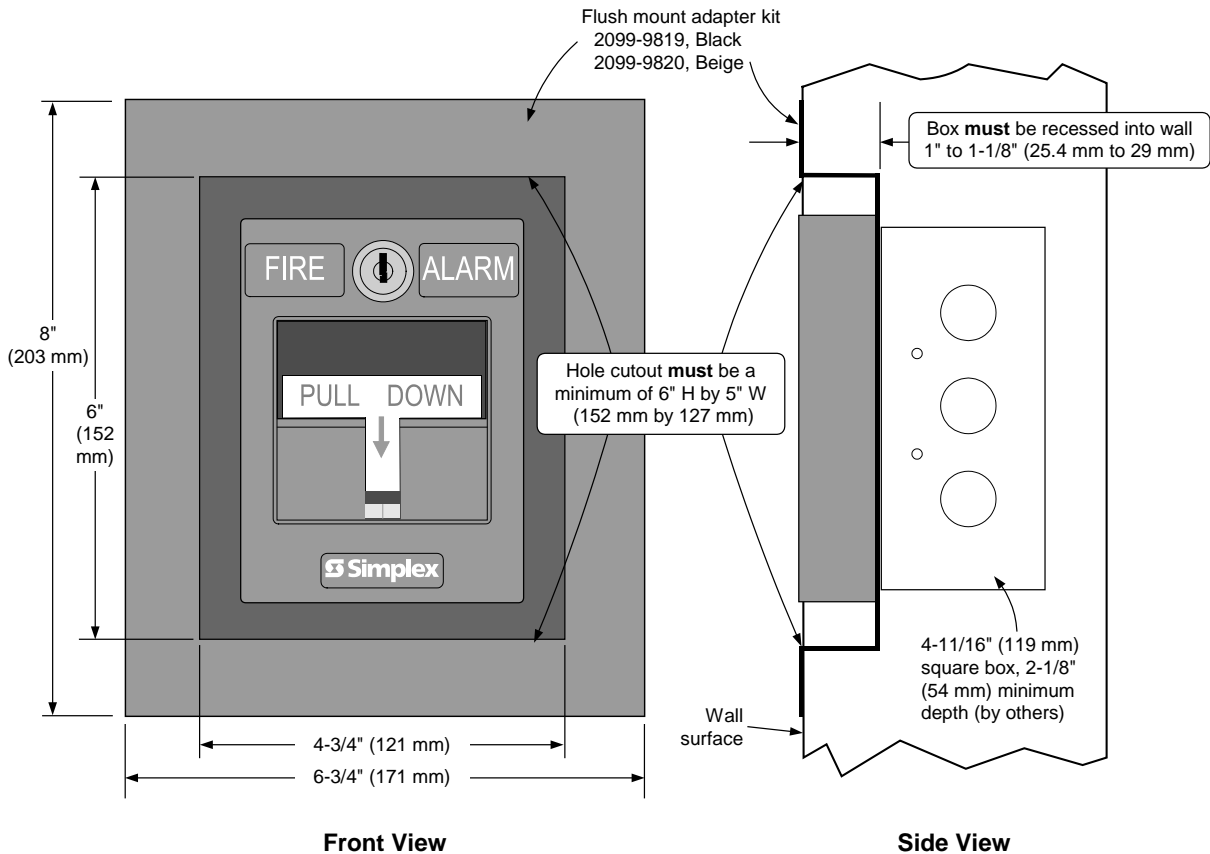

Intrinsically Safe Product Selection

Barrier Modules

Model	Description	Notes
2081-9062	Single Channel Intrinsically Safe Barrier Module	Each module requires an 2081-9061 installation kit, and a 2975-9218 cabinet
2081-9063	Dual Channel Intrinsically Safe Barrier Module	

Required Accessories (ordered separately)

Model	Description	Notes
2081-9061	Intrinsically Safe Barrier Installation Kit	Includes barrier module mounting bracket, mounting hardware, control drawing, and required end-of-line resistors
2975-9218	Intrinsically Safe Barrier Cabinet	Cabinet is red with solid door and keyed lock

Intrinsically Safe Manual Stations (ordered separately)

Model	Description
2099-9767	Single Action Manual Station
2099-9799	Double Action Manual Station (Breakglass)

Manual Station Accessories

Model	Description	
2975-9178	Surface Mount Steel Box, Red	Refer to page 5 for details
2975-9022	Cast Aluminum Surface Mount Box, Red	
2099-9819	Flush Mount Adapter Kit, Black	Refer to page 6 for details
2099-9820	Flush Mount Adapter Kit, Beige	
2099-9803	Replacement Breakglass	
2099-9804	Replacement Break-Rod	

Compatible Smoke Detector (NOTE: Refer to page 2 for compatible IDCs)

Model	Description		
SLR-E-IS	Hochiki Intrinsically Safe Photoelectric Smoke Detector	Requires a YBN-R/4-IS detector base	This smoke detector and base has been tested for compatibility but is not agency listed or approved ; maximum of five (5) per circuit; available from Hochiki America
YBN-R/4-IS	Hochiki Intrinsically Safe Detector Base	Required for SLR-E-IS detector	

Entity Parameters and Maximum Total Wiring Lengths from Control Panel to Last Device in Hazardous Area*

Group	Maximum Capacitance	Maximum Inductance	Open Circuit Voltage (V _{oc})	Short Circuit Current (I _{sc})	18 AWG	16 AWG	14 AWG	12 AWG
A, B	0.14 μ F	3.84 mH	28.4 V	97 mA	781 ft (238 m)	1250 ft (381 m)	2000 ft (610 m)	2000 ft (610 m)
C, E	0.42 μ F	15.61 mH						3100 ft (945 m)
D, F, G	1.11 μ F	31.49 mH						

* Refer to Control Drawing 842-070 for complete information. Wiring distances provided are for individual conductors in conduit with assumed parameters of 60 pF/ft and 0.2 μ H/ft.

Metric wire equivalents: 18 AWG = 0.82 mm²; 14 AWG = 2.08 mm²; 12 AWG = 3.31 mm²

Tyco, Simplex, the Simplex logo, MAPNET II, and IDNet are trademarks of Tyco International Services AG or its affiliates in the U.S. and/or other countries. NEC, NFPA, and National Electrical Code are trademarks of the National Fire Protection Association.



Tyco Safety Products Westminster • Westminster, MA • 01441-0001 • USA
www.tycosafetyproducts-usa-wm.com

S2080-0018-3 10/2003

© 2003 Tyco Safety Products Westminster. All rights reserved. All specifications and other information shown were current as of document revision date and are subject to change without notice.