

Features

Photoelectric smoke detector with on-board TrueAlarm sensitivity drift compensation:

Functional chamber enclosure:

- Louvered design enhances smoke capture by directing flow to chamber
- Entrance areas are minimally visible when ceiling mounted
- Operation is for ceiling or wall mounting

Multi-function indicator LED indicates normal and alarm conditions

Magnetically operated functional test:

- Initiates alarm and verifies performance
- Identifies general sensitivity status using detector LED

Models available in two sensitivity settings:

- 4098-9601, Standard Sensitivity, nominal 2.8%/ft obscuration*
- 4098-9605, Special Application Sensitivity, nominal 3.5%/ft obscuration

Available options:

- Bases for 2-wire or 4-wire operation
- Auxiliary alarm relay output
- Remote alarm indicating LED

Designed for EMI compatibility

UL listed to Standard 268

Description

Simplex® TrueAlarm photoelectric detectors provide many of the proven TrueAlarm analog sensing features for applications where detectors are connected to conventional 2-wire or 4-wire initiating device circuits (IDCs). Each TrueAlarm detector has an on-board microprocessor that evaluates its photoelectric light scattering chamber activity and makes an intelligent decision based on light obscuration history as to whether an alarm condition is present.

TrueAlarm detectors are packaged in a patented housing that minimizes the visibility of the air intake louvers from the normal viewing locations while maintaining a high performance smoke capture ability. Bases are available for remote alarm LED indicator connections and auxiliary relay outputs.

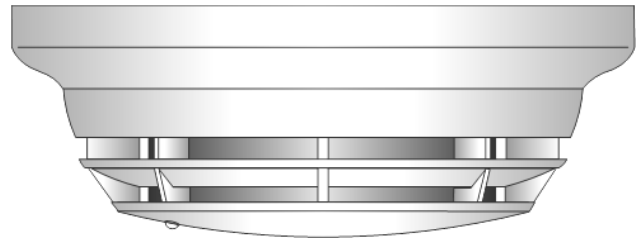

4098-9601 TrueAlarm Photoelectric
Detector Mounted in Base

Specifications

Voltage	15 to 32 VDC from Fire Alarm Control Panel IDC
Standby Current	100 μ A @ 24 VDC
Alarm Current, 2-Wire Operation	Up to 86 mA maximum, exact current is determined by alarm current limiting of connected IDC
Alarm Current, 4-Wire Operation	24 mA typical @ 24 VDC
Auxiliary Relay Ratings	Refer to page 2 under Product Selection
Air Velocity Range	0-2000 ft/min (0-610 m/min)
UL Listed Temp. Range	32° to 100° F (0° to 38° C)
Operating Temp. Range	15° to 122° F (-9° to + 50° C)
Storage Temp. Range	0° to 140° F (-18° C to 60° C)
Humidity Range	10% to 95% RH from 32° to 122° F (0° to 50° C) non-condensing
Color	Frost White
Dimensions	4-7/8" Dia. x 1-7/8" H, mounted in base (124 mm x 48 mm); refer to page 3 for detail

* ULC listed model is 4098-9601. This product has been approved by the California State Fire Marshal (CSFM) pursuant to Section 13144.1 of the California Health and Safety Code. See CSFM Listing 7272-0026:219 for allowable values and/or conditions concerning material presented in this document. Accepted for use – City of New York Department of Buildings – MEA35-93E. Additional listings may be applicable; contact your local Simplex product supplier for the latest status. Listings and approvals under Simplex Time Recorder Co. are the property of Tyco Fire Protection Products.

TrueAlarm Smoke Detector Features

Intelligent Data Evaluation. Conventional smoke detectors will typically drift toward being too sensitive due to the accumulation of dust and dirt. With TrueAlarm analog detection, data from the photoelectric chamber is monitored and analyzed at the detector to provide a continuously shifting reference point.

Drift Compensation. The data evaluation and its shifting reference point provide a software filtering process that compensates for environmental factors (dust, dirt, etc.) and component aging, establishing an accurate reference for evaluating new activity. With this filtering, the resulting drift compensation provides a significant reduction in the probability of false or nuisance alarms caused by shifts in sensitivity – either up or down.

Magnetic Test Information. Status information is available by performing the magnetic test and observing the detector LED pulses. The LED will normally go directly into alarm with the magnetic test. If there is an off-normal condition, the LED pulses first to indicate the condition and then goes into alarm. (See page 3.)

Application Reference

Detector Locations. Locations should be determined only after careful consideration of the physical layout and contents of the area to be protected. Refer to NFPA 72, the *National Fire Alarm Code*. On smooth ceilings, smoke detector spacing of 30 ft (9.1 m) may be used as a guide. For detailed installation information, refer to *4098 Detectors, Sensors, and Bases Application Manual* (574-709).

Sensitivity Selection. The 4098-9601 standard sensitivity detector is recommended for most applications. When a special application for a reduced sensitivity detector is required, the 4098-9605 should be considered. Consult your local Simplex product supplier for assistance in determining the proper selection.

Product Selection

Smoke Detectors

Model	Nominal Sensitivity	Description	Compatibility
4098-9601	2.8%/ft (standard)	TrueAlarm Photoelectric Detector	Compatible with bases: 4098-9788, 4098-9682, and 4098-9683
4098-9605	3.5%/ft (special application sensitivity, not ULC listed)		

Compatible Bases

Model	Description	Details*
4098-9788	2-Wire Base with connections for Remote Alarm LED Indicator	IDC and LED connections are screw terminals for in/out wiring, 18 to 14 AWG
4098-9682	4-Wire Base with Auxiliary Alarm Relay Contacts and connections for Remote LED Alarm Indicator NOTE: Requires external 24 VDC for operation	Relay Ratings, Single Form "C", For Suppressed Loads: Power limited, 3 A @ 28 VDC; Non-power limited, 3 A @ 120 VAC Wiring Connections (In/Out where required): Relay contacts and IDC wiring, color coded 18 AWG leads; LED wiring, screw terminals for 18 to 14 AWG
4098-9683	2-Wire Base with Auxiliary Alarm Relay & connections for Remote LED Indicator NOTE: Must be connected as the only device on the IDC to ensure relay operation.	Relay Ratings, Dual Form "C", For Suppressed Loads: Power limited, 1 A @ 28 VDC; Non-power limited, 1/2 A @ 120 VAC Wiring Connections (In/Out where required): Relay contacts and IDC (-), color coded 18 AWG leads; IDC (+) and LED wiring, screw terminals for 18 to 14 AWG

Detector Accessories

Model	Description	Details*
4098-9832	Adapter Plate	Required for mounting to surface mounted 4" (102 mm) square or 4" octagonal boxes, and to 4" square flush mounted boxes May be used when retrofitting existing bases Compatible with detector bases 4098-9788, -9682, & -9683
4098-9830	Remote LED Indicator	Mounted on single gang stainless steel plate
2098-9739	Encapsulated	24 VDC End-of-Line Relay Dimensions: 2-1/2" x 1-1/2" x 1" (64 mm x 38 mm x 25.4 mm) Mounted on single gang stainless steel plate
2098-9735	Plate Mounted	
		Required for 4-wire circuits using 4098-9682 base, one per circuit; select mounting type as required; wiring is color coded 18 AWG wire leads

* Refer to pages 3 and 4 for dimensions and additional mounting details; 18 AWG = 0.82 mm²; 14 AWG = 2.08 mm²

Detector Status LED Indications

LED Indication	Status
Pulses approximately every 4 seconds	Normal
Steady On	Alarm

LED Response to Magnetic Test *

LED Indication	Followed By	Status	Action
LED turns ON	Alarm is initiated	Normal , sensitivity is within compensation range	None
LED pulses quickly, 6 times in 3 seconds, then turns ON	Alarm is initiated	More sensitive , out of normal compensation range	Cleaning or other service is required
LED pulses slowly, 4 times in 8 seconds, then turns ON	Alarm is initiated	Less sensitive , out of normal compensation range	
	Does not initiate Alarm	Detector is malfunctioning	Service is required

* Testing requires placing a magnet at the designated location on the detector cover for 4 seconds. Refer to Application Manual 574-709 for further test and maintenance information.

Dimensions and Reference Information

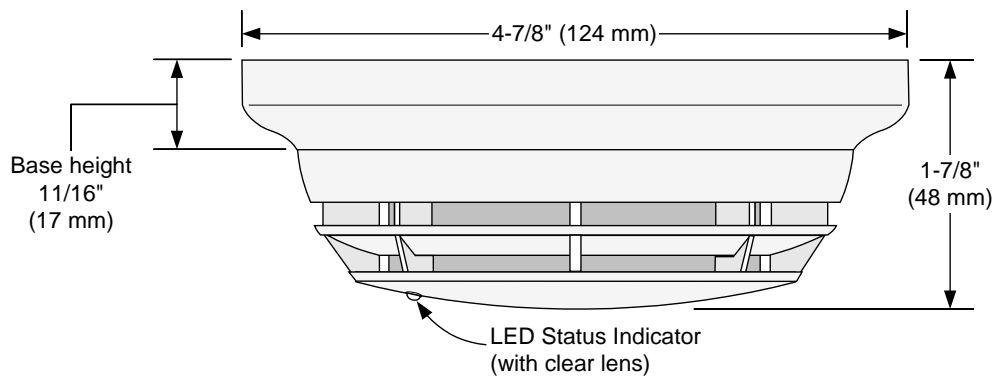
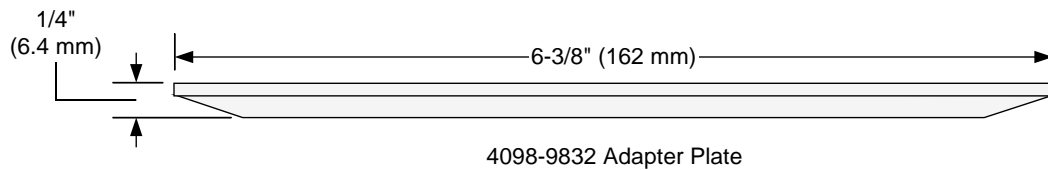

4098-9601 & -9605 Dimensions Mounted on Base

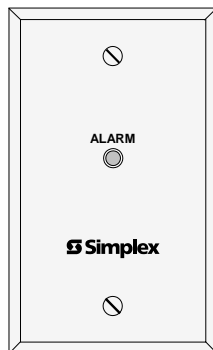

4098-9830 Remote LED Indicator (not to scale)

Mounting Information

(Electrical boxes are supplied by others.)

Electrical Box Requirements:

Without relay (base 4098-9788):

4" octagonal or 4" square, 1-1/2" deep

Single gang, 2" deep

With relay (bases 4098-9682 and 4098-9683):

4" octagonal, 1-1/2" deep, with 1-1/2" extension ring

4" square, 1-1/2" deep, with 1-1/2" extension ring

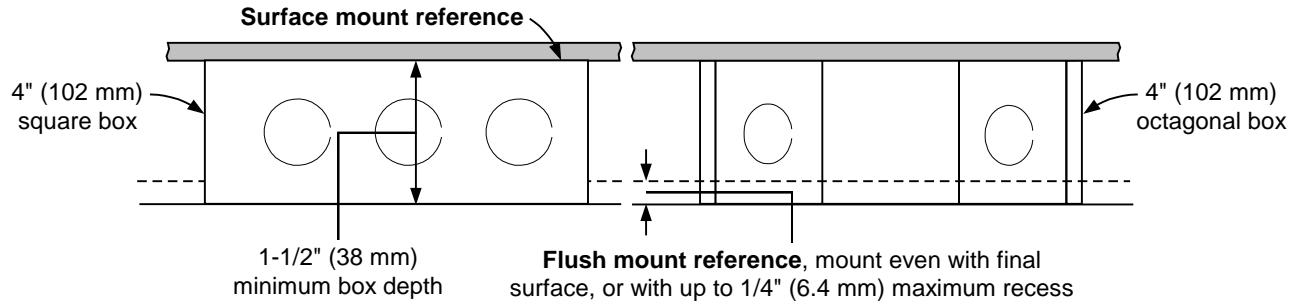

4098-9832 Adapter Plate, required for mounting to surface mounted boxes and to 4" square flush mount boxes

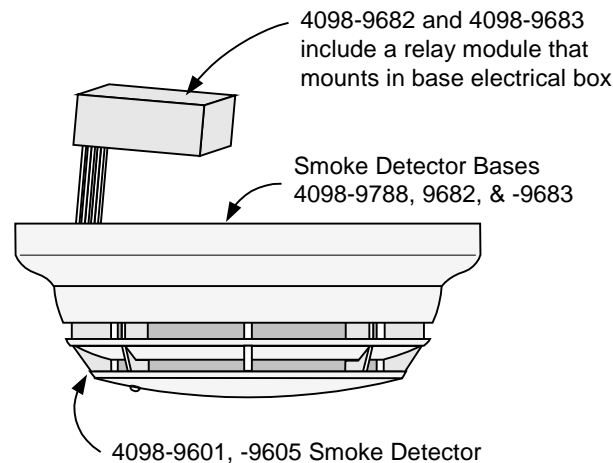

TYCO, SIMPLEX, and the product names listed in this material are marks and/or registered marks. Unauthorized use is strictly prohibited. NFPA 72 and National Fire Alarm and Signaling Code are registered trademarks of the National Fire Protection Association (NFPA).