

Features

Fire alarm control panel designed specifically for suppression release operation with:

- Four initiating device circuits (IDCs)
- Two notification appliance circuits (NACs)
- Two releasing appliance circuits (RACs)
- Two special purpose monitor inputs (SPMs) that accept manual release request and manual abort request for Agent Release systems, and waterflow and supervisory for Preaction or Deluge systems
- Three auxiliary relays with selectable functions
- Easily selected activity timing options

Suppression release operation includes:

- Automatic extinguishing release
- Deluge and preaction sprinkler system release
- Dual or single hazard area protection
- *Combined agent release and preaction operation***
- IDCs are selectable for cross-zoning or for activation from a single detection input
- Short circuit RAC supervision
- Compatible with Listed/Approved 24 VDC or 2, 12 VDC series connected actuators

Audible Escalation of Events:

- **Single Audible Appliance Tone:** Stage 1 activates Temporal or 20 bpm March Time pattern; Stage 2 activates 120 bpm March Time pattern to indicate release timer active; Release activates On Steady to indicate release timer expired and actuator is activated
- **Dual Audible Appliance Control** (Single Hazard):** RAC 2 provides a third NAC for dedicated Stage 1 Bell control; NACs 1 & 2 indicate release as On Steady

Operator interface provides:

- Status LEDs per circuit for Alarm, Trouble, and Supervisory (where appropriate)
- Acknowledge, Alarm Silence, and System Reset
- Operating mode selection and timer selections when in programming mode

Related system components:

- Coil supervision module 2081-9046, one per RAC
- Maintenance Switch, one per RAC
- Abort Switch

Listed to

- UL Standard 864 and ULC Standard S527

Introduction

Dedicated for Suppression Release. 4004R Suppression Release Panels provide conventional fire alarm control circuits and are equipped with the features required for a wide variety of single or dual hazard suppression release applications. Capabilities include automatic extinguishing agent release and deluge and preaction sprinkler control.

** Requires Software Revision 4.01 or higher.

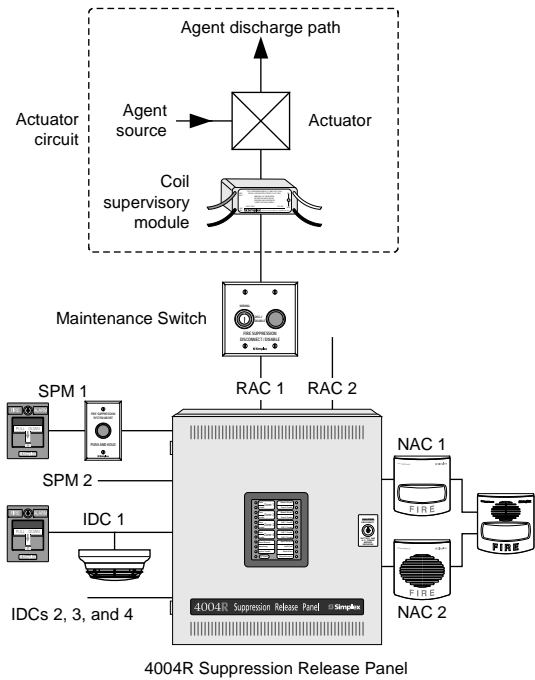

4004R Suppression Release Panel
One-Line System Reference Drawing

Introduction (Continued)

Flexible I/O Capabilities. Four IDCs allow for either four separately monitored zones or two, cross-zoned connections. Two SPMs allow dedicated manual inputs for release or abort; for waterflow and supervisory, or release/abort and pressure, depending on system type. Two releasing appliance circuits (RACs) supervise to the actuator coils and activate the actuators when required. The two NACs and the three panel auxiliary relays provide status condition information.

Easy Program Selections. The operator panel has a program mode that allows selection of panel operation type and detailed operating selections using an easily selected sequential programming operation.

History Log. The last 50 events are stored in non-volatile memory. This information is accessed by connecting a technician's computer to the service port which is also used to set the date and time.

Panel Feature Description

Operator Panel. The operator panel has alarm and trouble status indicating LEDs for each input and output, visible through the locking cabinet door (refer to diagram on page 4). Unlocking the door provides access to the Acknowledge, Alarm Silence, and System Reset pushbutton switches.

* This product has been approved by the California State Fire Marshal (CSFM) pursuant to Section 13144.1 of the California Health and Safety Code. See CSFM Listing 7165-0026:314 for allowable values and/or conditions concerning material presented in this document. Additional listings may be applicable; contact your local Simplex® product supplier for the latest status. Listings and approvals under Simplex Time Recorder Co. are the property of Tyco Fire Protection Products Westminster.

Panel Feature Description (Continued)

(Refer to specifications on page 6 for more information.)

Four Class B IDCs provide coverage for either two cross-zoned areas or four separately zoned areas. IDCs are capable of supporting up to 30 Simplex current-limited smoke detectors or electronic heat detectors (see list on page 2) as well as manual stations and other compatible contact closure initiating devices. IDCs are capable of Class A operation with an optional adapter module and can be programmed as Style C (short or open initiates a trouble) for use with current limited devices only. Single hazard agent release applications monitor pressure switches with IDC 3 and tamper switches with IDC 4.

Two Class B Special Purpose Monitoring Circuits (SPMs) are dedicated for manual release or abort, waterflow and supervisory, or release/abort and pressure, depending on system type. Inputs are normally open switches. An abort switch stops release while activated and upon deactivation, the release operation occurs after a selectable time delay. Manual release inputs override abort switches and activate the release after selectable delays of from 0 to 30 seconds in 5 second increments. For Dual Hazard applications, current limited abort operation is required. SPMs are programmable as Style C and capable of Class A operation with the optional adapter module.

Two Class B NACs are provided for reverse polarity, notification appliance operation, each rated 2 A. Class A operation is available with the optional adapter module. NAC operation is selectable per application. Synchronized strobe operation requires a separate 4905 Series Strobe Synchronization Module (see product selection below), and a continuous, steady-on (non-coded) input from the NAC.

Two Class B Releasing Appliance Circuits (RACs). Rated 2 A each, these circuits are dedicated to operating release control actuators. RAC cutout timing is selectable as no cutout, 45 seconds, or 1, 3, 3.5, 4, 5, 6, 7, 21, 25, 34, 44, or 64 minutes. For bell/horn/strobe single hazard applications, RAC 2 functions as a third NAC (NAC 3).

Auxiliary Power Output. Two sets of output terminals are provided, one for continuous operation and the other for resettable operation, rated for 750 mA combined. Resettable terminals are provided for 4-wire smoke detector power.

Standard Panel Auxiliary Relay Outputs. Three relay outputs are available, selectable as normally open or normally closed, rated 2 A @ 30 VDC, 0.35 p.f. inductive:

Aux Relay 1 (Trouble) is energized when Normal and is de-energized with a common Trouble condition.

Aux Relays 2 and 3 respond differently depending on the system type and whether single or dual hazard. Typical functions are:

For Single Hazard Operation, Aux Relay 2 is the common Alarm relay. Aux Relay 3 can be selected to indicate pre-discharge (release time delay started), common supervisory, waterflow, or pressure switch relay, depending on the system type.

For Dual Hazard Operation, Aux Relay 2 is for Hazard Area 1 common Alarm; Aux Relay 3 is for Hazard Area 2 common Alarm.

Power Supply and Battery Charger. During alarm, the power supply provides 3 A at 25.5 VDC, filtered and regulated. The temperature compensated battery charger provides 27.5 VDC for charging batteries up to 12.7 Ah, suitable for up to 90 hour standby and 10 minutes of alarm. A 4081 Series external battery cabinet with charger can be used for more battery backup (see battery selection below).

Product Selection

Release Control Panels

Model	Color	Listings	Description
4004-9301	Beige	UL, ULC, CSFM, & FM	Basic Releasing Panel; operates with AC input of: 120/220/230/240 VAC, 50/60 Hz (auto-select); includes: four IDCs, two NACs, two SPMs, two RACs, 3 auxiliary relays, 3 A power supply with battery charger, and NEMA 1/IP30 rated cabinet and door
4004-9302	Red	UL, ULC, CSFM, FM, & MEA (NYC)	

Expansion Modules

Model	Description	Reference
4004-9860	Auxiliary Relay Module; four dual contact relays selectable as N.O. or N.C.; rated 7 A @ 120 VAC resistive, 5 A @ 30 VDC, 0.35 p.f. inductive; unsupervised contacts	Two maximum
4004-9864	Two Circuit Class A Adapter Module for IDCs, SPMs, or NACs	Four maximum

System Batteries

Model	Description	Reference
2081-9272	6.2 Ah battery, 12 V	These batteries can be mounted in the 4004R cabinet; select one battery model per system standby requirements; two batteries are required; for more capacity see data sheet S4081-0001 for a compatible external battery cabinet with charger
2081-9274	10 Ah battery, 12 V	
2081-9288	12.7 Ah battery, 12 V	

Release Control Systems Accessories (refer to additional information listed on page 3)

Model	Description
2081-9046	Coil Supervision Module, one required per RAC ; refer to pages 6 and 7 for detail
2081-9048	Abort Supervision Module; encapsulated 560Ω, 1/2 W resistor; for Dual Hazard SPM; allows non-current limited Abort and Manual Release stations to be on same circuit; refer to pages 6 and 7 for detail
4081 Series	End-of-Line Resistor Harnesses; refer to data sheet S4081-0003
2099 Series	Manual Stations for Releasing Applications; refer to data sheet S2099-0010
4905-Series	Strobe synchronization modules; 4905-9914 for Class B, 4905-9922 for Class A; see data sheet S4905-0003 for details

Reference Information, Compatible Simplex Detectors and other System Components

Model	Type		Data Sheet
4098-9601	Standard detector	Photoelectric smoke detectors for 2-wire and 4-wire bases	S4098-0015
4098-9605	Reduced sensitivity detector		
4098-9602	Combination smoke and heat detector		
4098 Series	Ionization Smoke Detectors; 2-wire and 4-wire models		S4098-0018
4098-9612	135° F (57°C)	Fixed heat detector	Electronic heat detectors for 2-wire and 4-wire bases
4098-9614	200° F (93°C)		
4098-9613	135° F (57°C)	Fixed with rate-of-rise heat detector	
4098-9615	200° F (93°C)		
2099-9149	Standard	Manual Release Station with selectable release labels; double action push, N.O. contact	
2099-9152	Style C, with 560 Ω internal resistor		
2080-Series	Maintenance Switches, flush or surface mount; indicator lamps require 24 VDC wiring		S2080-0010
	Abort Switches, surface or flush mount; available standard or with 1.2 kΩ, 1 W resistor		

Expansion Modules and Accessories

Auxiliary Relay Module 4004-9860 provides four additional relays. Dual hazard applications will require two modules for auxiliary relay operation. Each relay module has a manual disconnect switch that controls relays 2 through 4. (Trouble Relay 1 is not controlled.) Relay outputs are required to be connected to a 15 A maximum circuit breaker. (Relay specifications are detailed on page 6.)

Auxiliary Relay Module Operation:

Relay 1 activates on a common **trouble** associated with its hazard or a system trouble.

Relay 2 activates on a common **alarm** associated with its hazard.

Relay 3, selected for original operation, activates for pressure switch, waterflow switch, or release timer as required per application type (hazard specific), or activates with the second zone for cross-zoned systems (hazard specific). "Original" operation allows direct panel replacement if required.

Relay 3, selected for enhanced operation, (software 4.01 or higher), activates to indicate pre-discharge, supervisory, or waterflow (application specific).

Relay 4 activates when the hazard specific RAC activates or with pressure switch input (application specific).

Dual Circuit Class A Adapter Module 4004-9864.

This module converts two Class B circuits to Class A operation. It consumes no additional current and is compatible with IDCs, SPMs, and NACs. Up to four modules may be mounted within the 4004R cabinet.

Abort Switches. For manual abort requests, these abort switches are available with or without a built-in 1.2 kΩ, 1 W resistor and are mounted on single-gang stainless steel plates. Abort switches are connected to the SPM inputs per system requirements.

Activity abort occurs while the switch is pushed and continues after releasing the switch for the selected Abort Release Time Delay. (See drawing below.)

Maintenance Switch. Proper service of release appliance circuits requires the ability to securely disconnect the release circuit during installation and maintenance. Simplex maintenance switches are controlled by keyswitch and initiate a supervisory condition when in disconnect/disable position. Models with lamp are on a double-gang plate and are powered from separate 24 VDC wiring. Mounting is on stainless steel plates and models are available as either surface or flush mount. (See drawing below.)

For additional Maintenance and Abort Switch information refer to data sheet S2080-0010.



Abort Switch



Maintenance Switch

Programming Modes and Selection Choices

Sequence	Select <u>one</u> of 13 Application Modes (numbered 1 through 13 in <i>italics</i>)					
1	Agent Release	Single Hazard	Cross-Zoned	1	Combined Release (RACs activate together)	
			Either Zone	2		
		Dual Hazard	Cross-Zoned	3		Independent Release (RACs are separate)
			Either Zone	4		
	Preaction/Deluge	Single Hazard	Cross-Zoned	5	Combined Release (RACs activate together)	
			Either Zone	6		
		Dual Hazard	Cross-Zoned	7		Independent Release (RACs are separate)
			Either Zone	8		
	Agent Release; Single Hazard	Cross-Zoned	9	NYC Abort (not UL listed)		
	Agent Release & Preaction; Single Hazard	Cross-Zoned	10	RAC 2 provides Preaction Control; RAC 1 is Agent Release Control		
		Either Zone	11			
	Agent Release, Bell/Horn/Strobe; Single Hazard	Cross-Zoned	12	RAC 2 operates as NAC 3 for Stage 1 Bell Control (separate sound from release alarm)		
		Either Zone	13			

Sequence	Programming Mode Description	Description	
2	Select Relay Operation for Application Modes 1-9	Select "Original" operation mode or "Enhanced" mode (refer to Auxiliary Relay 3 information on page 3 for details)	
3	IDC and SPM Circuit Style	Class B/Class A or Style C	
4	Automatic Release Time Delay	Selectable in 5 second increments from 0 to 60 seconds (default is 60 seconds)	
5	RAC Cutout Timer	No cutout, 45 seconds, or 1, 3, 3.5, 4, 5, 6, 7, 21, 25, 34, 44, or 64 minutes	
6	Manual Release Time Delay	0, 5, 10, 15, 20, 25, or 30 seconds	
7	Abort Release Time Delay	UL Standard 864 listed	Immediate or 10 seconds remaining
		Not UL Standard 864 listed	IRI abort (cross-zoned systems only), NYC abort, or original release delay
8	NAC Coding (where selectable)	Temporal pattern or 20 beats per minute (first cross-zone alarm)	
9	Standard Operation	No inhibit or one minute inhibit selected as: both on until silence, NAC 1 on until reset and NAC 2 on until silence, or both on until reset;	
	Pre-Discharge Operation	NOTE: For Halon 1301, Halon 1211, or clean agent release, a pre-discharge NAC must be configured to warn of impending discharge, the release timer selects the duration of the pre-discharged signal	
10	Supervisory Latching	Latching or non-latching	
11	Supervisory Notification	LED and tone-alert only, or with: NAC 2 also on; Aux Relay 3 also on; or both NAC 2 and Aux Relay 3 also on	

Operator Panel Function Reference

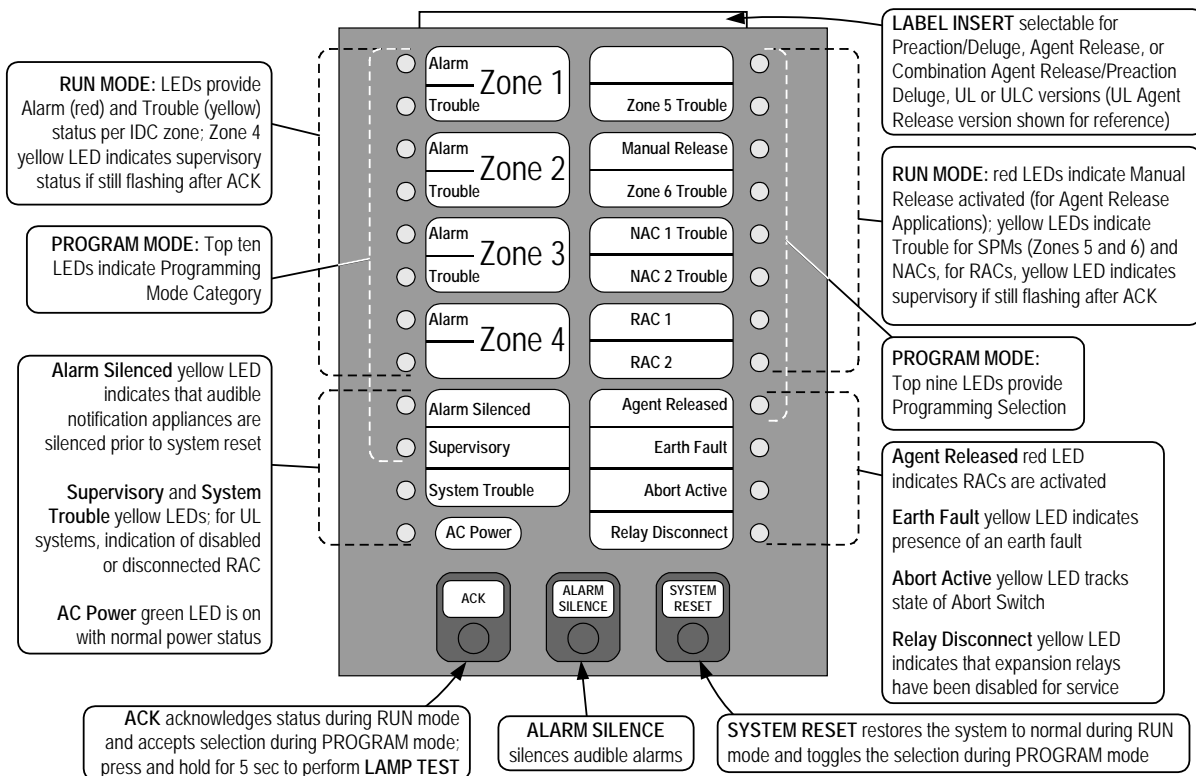

Release Control System Reference

Automatic Extinguishing Release Systems

automatically activate actuators for the release of a fire extinguishing agent (dry chemical, water spray, foam, CO₂, Clean Agent, etc.) in response to fire detection device input.

Automatic Extinguishing Release Systems with Separate Bell Control (single hazard)

(SW rev. 4.01 or higher). RAC 2 operates as a bell control NAC. When cross-zoned, stage 1 alarm activates the bell until the release timer starts. When not cross-zoned, stage 1 alarm activates the bell until expiration of the release timer. In both cross-zoned and non cross-zoned applications, NAC2 may be programmed to indicate either a tamper switch supervisory condition or the start of the release timer using a cadence pattern operation.

UL and FM Extinguishing Release System Panels

must have a minimum of 24 hours of standby power. Initiating devices must be Listed/Approved for the application, and may be wired either Class A or B. Actuators must be electrically compatible with the control panel circuits and power supplies, and are wired Class B to provide coil supervision. (See details in next section.)

Deluge and Preaction Sprinkler Systems

automatically activate water control valves in response to fire detection device input.

Deluge Sprinkler Systems employ open sprinkler heads and provide water flow when the fire detection system activates a common automatic water control valve. They are used to deliver water simultaneously through all of the open sprinkler heads. This type of system is applicable where the immediate application of large quantities of water over large areas is the proper fire response.

Preaction Sprinkler Systems are similar to deluge systems except that normally closed sprinkler heads are used and supervisory air pressure is maintained in the pipe. Operation requires both an activated sprinkler head and an activated fire alarm initiating device.

Combined Agent Release and Preaction Systems

provides agent release *and* preaction control. (Available with software revision 4.01 or higher.) For applications where agent release may not be sufficient for fire control, sprinklers are put in preaction mode to allow waterflow to continue the fire response. (Preaction is assumed, selected deluge could be provided, determined by the sprinkler installation, panel operation is the same.)

UL requirements for Fire Alarm Systems Listed for Automatic Release or Deluge and Preaction Sprinkler Systems are the same as described above for Automatic Extinguishing Release Systems.

FM Approved requirements for Fire Alarm Systems for Automatic Release of Deluge and Preaction Sprinkler Systems require operation of specific compatible FM Approved Automatic Water Control Valves, a minimum secondary power capacity of 90 hours, and all circuits for the automatic release initiating devices must be capable of operation during a single open circuit fault condition (Class A).

PLEASE NOTE: Proper operation of release control systems requires that the system design, installation, and maintenance be performed correctly and in accordance with all applicable local and national codes, and equipment manufacturer's instructions. No liability for total system operation is assumed or implied.

Release Control System Requirements

1. Actuators are connected as two-wire, Class B notification/releasing circuits **with only one 24 VDC actuator per circuit** to ensure supervision. Where applicable, two, 12 VDC actuators in series, or one 12 VDC actuator and a manufacturer supplied series resistor may be used.
2. Coil Supervision Module, model 2081-9046, must be wired electrically before the actuator and located in the actuator wiring junction box. (See diagram on page 7.)
3. For UL Listed Automatic Extinguishing Release valves and actuators, refer to list on page 7.
4. For FM Approved Automatic Extinguishing Release, secondary standby must be a minimum of 24 hours with 5 minutes of alarm. Actuators must be electrically compatible.
5. For FM Approved Deluge and Preaction Sprinkler operation: IDCs must be Class A, wired to Listed/Approved devices; secondary standby capacity must be a minimum of 90 hours with 10 minutes of alarm; and the specified compatible Automatic Water Control Valves/Actuator must be used. (See list on page 8.)
6. Power supply loading and wiring distances must be per Installation Instructions 579-354.
7. Battery standby must be selected for proper actuator operation and may require a minimum voltage of 23 VDC depending on the actuator. Detailed battery calculation reference information is contained in Installation Instructions 579-354.
8. Maintenance Switches, one per RAC, are required per NFPA 72, the *National Fire Alarm and Signaling Code*, to allow the system to be tested or serviced without actuating the fire suppression systems. *Their use may not be allowed in some jurisdictions, always confirm local requirements.* When used, Simplex Maintenance Switches are required to ensure that operation initiates a supervisory condition.

Additional System Device Information

1. Simplex Abort Switches are available when abort operation is required. When used, wire on Special Purpose Monitoring Circuits (SPMs) as Class A or Class B; Simplex model Abort Switches are required.
2. Manual Release Stations are used for direct activation of the release actuators with the appropriate time delay implemented by the fire alarm control panel.
3. See pages 2 and 3 for additional reference information.

Additional Information

This data sheet is a summary of the extensive operating features and options available with the 4004R Release Control Panel. Complete details are covered in the *4004R Installation, Programming, and Operating Instructions* manual (publication 579-354) shipped with each 4004R. Compatible system devices are listed on page 3. For general information, refer to Factory Mutual Research Corporation (FMRC) "FMRC Approval Guide," FM Approval standard "Deluge Systems and Preaction Systems."

Specifications (Refer to diagram on page 7 and Instructions 579-354 for additional information)

Power Ratings

AC Input	Voltage Ratings	120 VAC, 60 Hz; 220/230/240 VAC, 50/60 Hz, auto-select
	Current Ratings	2 A maximum @ 120 VAC input; 1 A maximum @ 240 VAC input
Power Supply Output		3 A maximum available for external loads
Battery Charger		Temperature compensated, capable of recharging batteries required for 90 hour standby and 10 minute alarm (contingent on auxiliary power load)
Standby Current		100 mA; with IDCs fully loaded, tone-alert silenced, trouble LED on, charger off
Alarm Current		264 mA + external loads; (2 zones in alarm & 2 internal relays, NACs and RACs on)

Standard Circuit Ratings (NOTE: Total DC current = 3 A maximum; see NAC ratings for details)

Initiating Device Circuits (IDCs)	Supervisory	3 mA maximum; 3.3 kΩ end-of-line resistor per circuit
	Alarm Current	75 mA maximum
	Output Voltage	28 VDC maximum
	Capacity	Each IDC supports up to 30 detectors (smoke or electronic heat) and manual stations as required; wiring distance is limited to 50 Ω maximum
Special Purpose Monitoring Circuits (SPMs)	Application	For Manual Release, Abort Switches, or Supervisory functions only; not for detectors; wiring distance is limited to 50 Ω maximum
	For Dual Hazard Applications	Dual Hazard Application Abort Switches require a current limiting resistor of 1.2 kΩ, 1 W, or an external Abort Supervision Module per SPM
	Supervisory	6 mA; 3.3 kΩ end-of-line resistor per circuit
	Activated	75 mA maximum
	Output Voltage	28 VDC maximum
Notification Appliance Circuits (NACs)	Alarm Current	Special Application appliance rating = 2 A maximum on a NAC NOTE: Special Application appliance rating = full 3 A power supply rating
	Output Voltage	Regulated 24 DC appliance power = 1.5 A maximum on a circuit NOTE: Regulated 24 DC strobe load = 1.35 A maximum total for power supply
	Synchronized Strobe Operation	Requires NAC dedicated to strobe control with non-coded output; use an external Synch Module (4905-9914, Class A, or 4905-9922, Class B, see data sheet S4905-0003 for details); up to 33 strobes can be synchronized per 4004R
	Special Application Appliances	Simplex 4901 Series horns, 4904 and 4906 Series strobes, 4903 Series 4-wire horn/strobes; refer to Installation Instructions 579-354 for additional details
Notification Appliance Reference	Regulated 24 DC Appliances	Power for other appliances listed to UL Standard 1971 or UL Standard 464; use associated external synchronization modules where required
	Output Current	2 A maximum per circuit
Release Appliance Circuits (RACs)	Output Voltage	Activated = 26 VDC maximum; non-alarm = 29 VDC maximum; 10 kΩ end-of-line resistor
	Auxiliary Power Output; for Special Application loads only	Two outputs are available, continuous operation or resettable operation; combined output is 750 mA maximum; output voltage = 19.25 to 27 VDC
Auxiliary Relay Outputs (Trouble, Aux Relay 2, Aux Relay 3)		Contacts rated 2 A @ 30 VDC, 0.35 p.f., inductive, selectable as N.O. or N.C. by jumper
Wiring Connections for Above and AC Input		Terminals rated for 18 AWG to 12 AWG (0.82 mm ² to 3.31 mm ²)

Auxiliary Module Ratings

Class A Adapter Module 4004-9684		Two circuits per module, rated same as circuits; not applicable to RACs (no additional current required)
Auxiliary Relay Module 4004-9860	Relay Type	Four relays with two outputs per relay; individually selectable as N.O. or N.C.
	AC Ratings	7 A @ 120 VAC, resistive
	DC Ratings	5 A @ 30 VDC, 0.35 power factor, inductive
	Module Current	12 mA standby; 70 mA with all four relays energized; @ 24 VDC
	Wiring	Terminals rated for 18 AWG to 12 AWG (0.82 mm ² to 3.31 mm ²)

2081-9046 Coil Supervision Module and 2081-9048 Abort Supervision Module (see page 7 for additional details)

Construction	Epoxy encapsulated
Dimensions	1-3/8" W x 2-7/16" L x 1-1/16" H (34 mm x 62 mm x 27 mm)
Wiring	18 AWG (0.82 mm ²) wire leads, color coded
Coil Supervision Module Current Rating	2 A maximum; internally fused at 3 A, non-replaceable
Abort Supervision Module Resistance	560 Ω, 1/2 W

Environmental Ratings

Operating Temperature Range	32° to 120°F (0° to 49° C)
Operating Humidity Range	up to 93% RH, non-condensing @ 100.4° F (38° C) maximum

4004R System Connection Reference

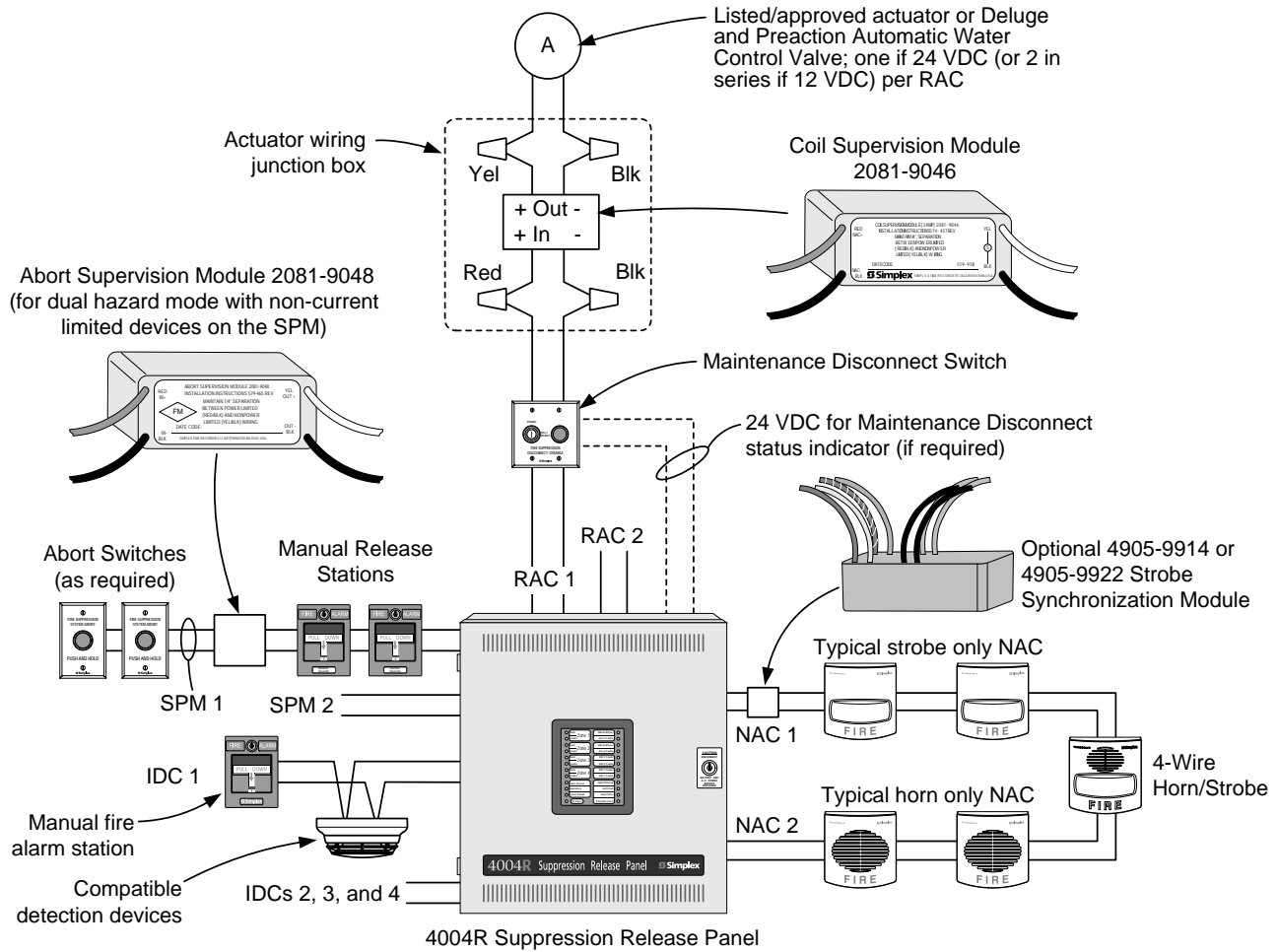

GENERAL WIRING NOTE:

Wiring shown is for reference only, refer to installation instructions for detailed wiring information.

Compatible UL Listed Valves and Actuators

MFG.	Model Number	Coil Details	MFG.	Model Number
ANSUL	*AUTOMAN II-C Assembly (solenoid 17728; coil 25924)	12 VDC, 458 mA	ASCO	8210A107 (097617-005D coil) 1/2" NPS, 5/8" orifice, 24 VDC
	AUTOMAN II-C Explosion-Proof Releasing Device (solenoid 31492; coil 31438)	24 VDC, 467 mA		8210G207 (238310 coil) 1/2" NPS, 1/2" orifice
	*AUTOMAN II-C Assembly (solenoid 68739; coil 25924)	12 VDC, 458 mA		8211A107 (097617-005D coil) 24VDC
	Solenoid Electric Actuator (solenoid 73111; coil 73097)	24 VDC, 1 A		HV2628571 (23810 coil) N.C. 1/2" NPS, 1/2" orifice
	*CV90 HF Electric Actuator 73327 (may use 73606 in-line resistor)	9 VDC max, 450 mA		HV2648581 (23810 coil) N.O. 1/2" NPS, 1/2" orifice
	LP CO2 w/ASCO solenoid 422934	24 VDC, 442 mA		R8210A107 (097617-005D coil) 1/2" NPS, 5/8" orifice
	LP CO2 double action 24 VDC solenoid 430948	24 VDC, 438 mA	T8210A107 (097617-005D coil) 1/2" NPS, 5/8" orifice	
	LP CO2 3-way selector valve solenoid 433419	24 VDC, 438 mA	Pyro-Chem	ECH Electrical Control Head (551201)
	Electric Actuator 24 VDC solenoid 570537	24 VDC, 250 mA		Explosion-Proof Electric Actuator (570147)
		Removable Electric Actuator (570209) 0.2 A		
LPG	Solenoid 26114002 for Solenoid Coupling Assemblies: 21006401 & 21006402; & LPG128/145/190/230-50/55 FM-200 valves; and LPG128-90UL iFLOW & FM-200 valves	24 VDC, 542 mA	Star Sprinkler	Model D deluge valve, with solenoid 5550
			Hygood	304.205.010 – Electrical Actuator Suppression Diode 304.209.001 – Electrical Actuator Bridge Rectifier
			Minimax	Model MX1230 without diode, 24 VDC, 1/2 in. NPT
Skinner	71395SN2ENJ1NOH111C2 (Skinner coil H111C2) 1/4", NPS, 1/16"			* 12 VDC coils, either wire two in series for 24 VDC activation, or, if available from manufacturer, use series resistor
	73212BN4TN00NOC111C2 (Skinner coil C111C2) 1/2", 5-300 psi			
	73212BN4TNLVNOC322C2 (Skinner coil C322C2) 1/2", NPS, 0.92 A, 250 psi			
	73218BN4UNLVNOH111C2 (Skinner coil H111C2)			
	73218BN4UNLVNOC111C2 (Skinner coil C111C2) 1/2", NPS, 5/8 in. orifice			

FM Approved Water Control Valves

Group	Manufacturer	Model Number	Details
A	Skinner	LV2L BX25*	24 VDC, 11 W, 458 mA, 1/2 inch NPS, 1/2 inch orifice
B	ASCO	T8210A107	24 VDC, 16.8 W, 700 mA, 1/2 inch NPS, 5/8 inch orifice
		R8210A107	
		8210A107	
C	Star Sprinkler	5550	24 VDC, part of Model D deluge valve
D	ASCO	8210G207	24 VDC, 10.6 W, 440 mA, 1/2 inch NPS, 1/2 inch orifice
E	Skinner	73218BN4UNLVNOC111C2*	24 VDC, 10 W, 420 mA, 1/2 inch NPS, 5/8 inch orifice
		73212BN4TN00NOC111C2	24 VDC, 10 W, 420 mA, 1/2 inch NPS, 5/8 inch orifice; 5-300 psi
F	Skinner	73212BN4TNLVNOC322C2	24 VDC, 22 W, 1/2 inch NPS, 920 mA, 250 psi (1725 kPa), 1/2 inch orifice
G	Skinner	71395SN2ENJ1NOH111C2	24 VDC, 10 W, 420 mA, 1/4 inch NPS, 1/16 inch orifice, 250 psi (1725 kPa) rated working pressure
I	Victaulic	Series 753-E solenoid valve	24 VDC, 8.7 W, 1/2 inch NPS, 364 mA, 300 psi (2069 kPa), 1/2 inch orifice
J	Viking	11591 and 11592	Normally closed (NC) Explosion proof solenoid valves, 24 VDC, 10 W, 1/2 inch NPS, 300 psi (2069 kPa), 4.1 Cv
		11595 and 11596	Normally open (NO)
K	Viking	11601 and 11602	NC solenoid valve, 24 VDC, 9 W, 1/2 inch NPS, 250 psi (1725 kPa), 6.2 Cv

* For new applications, LV2L BX25 has been replaced by model number 73218BN4UNLVNOC111C2.

Mounting Reference Information

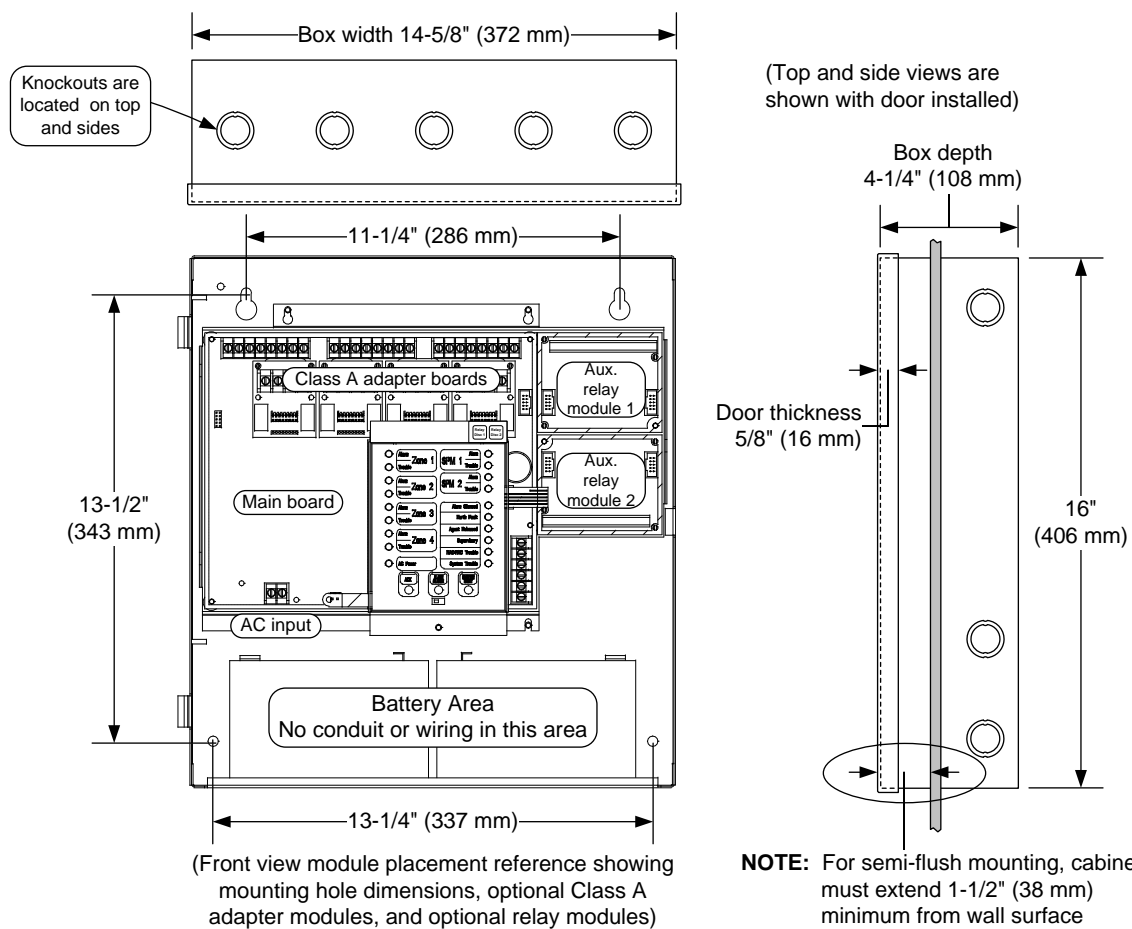

NOTE: A system ground must be provided for Earth Detection and transient protection devices. This connection shall be made to an approved, dedicated Earth connection per NFPA 70, Article 250, and NFPA 780.

TYCO, SIMPLEX, and the product names listed in this material are marks and/or registered marks. Unauthorized use is strictly prohibited. NFPA 72 and National Fire Alarm and Signaling Code are registered trademarks of the National Fire Protection Association (NFPA).



Tyco Fire Protection Products • Westminister, MA • 01441-0001 • USA
www.simplex-fire.com

S4004-0002-6 12/2015

© 2014 Tyco Fire Protection Products. All rights reserved. All specifications and other information shown were current as of document revision date and are subject to change without notice.