

Features

4009 IDNAC Repeaters provide enhanced power delivery to TrueAlert/TrueAlert ES addressable notification appliances controlled by IDNAC SLCs:

- Output voltage in alarm is maintained by an efficient switching regulator at 29 VDC during both AC input and battery backup conditions allowing strobes to operate at lower current
- With lower current strobes and regulated output voltage, wiring distance can be extended 2 to 3 times that of conventional notification, appliance loading can be increased, or smaller wire gauge can be used, all resulting in *installation savings* with high assurance that appliances that operate during normal system testing will operate during worst case alarm conditions

4009 IDNAC Repeaters receive an IDNAC SLC input and provide a repeated 3 A SLC output to extend SLC distance and power:

- Appliance control and address limit remains with the host IDNAC control panel. Repeater status is communicated to the control panel for system diagnostics and also locally indicated
- Repeater output extends supervisory capacity by up to 139 additional unit loads or 3 A
- Input SLC connection can be Class B or Class A
- Repeater output can be a Class A loop or a Class B output with internal connections for up to four (4) T-tapped output branches (Class A output requires 4009-9814 Class A Adapter)
- Operation requires one IDNAC SLC address; Repeaters can be connected as one in series, or up to five (5) in parallel
- AC power input is 120 VAC or 220-240 VAC, 50/60 Hz, auto-select
- An on-board battery charger is provided with low AC battery disconnect selectable per Repeater (required for ULC listed applications)
- Operation is compatible with TrueAlert ES and TrueAlert addressable notification appliances and accessories
- Available with platinum or red cabinet
- Listed to UL 864 and ULC S527

Multiple wiring options are available:

- Wiring options include Class B multiple branch (up to 4) output, Class A loop extension, and Class A riser to Class B branches or a Class A loop output
- When the Repeater is part of a Class A loop from the IDNAC SLC source panel, up to twice the distance for the loop is available; (Class A loop repeating requires 4009-9814 Class A Adapter)

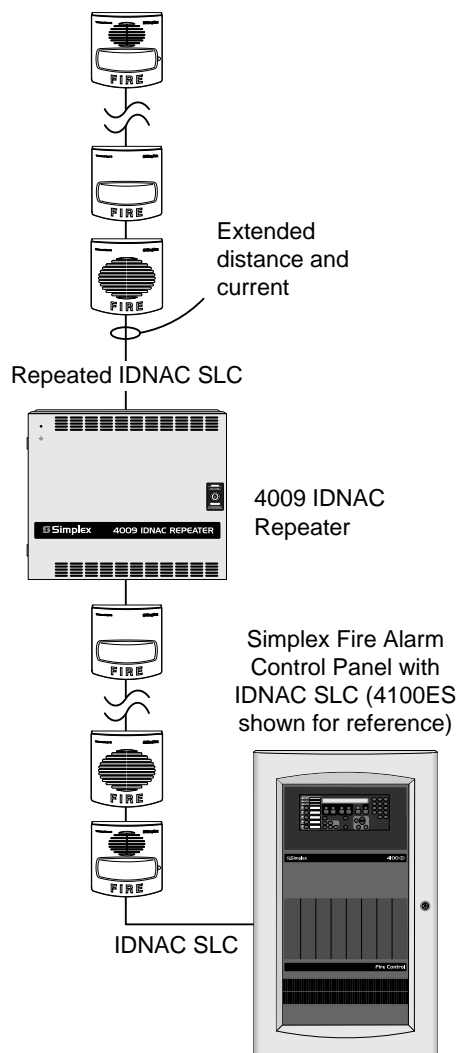

4009 IDNAC Repeater Extends Distance and Current of IDNAC SLC

Features (Continued)

Class A Adapter 4009-9814:

- Required when extending a Class A loop or to provide a Class A local loop SLC output
- Operation provides short circuit isolation between input and output terminals for improved IDNAC SLC survivability

Built-in battery Charger

- Power supply charges up to 12.7 Ah batteries for in cabinet mounting and up to 25 Ah batteries with model 4009-9801 external battery cabinet

Available auxiliary output:

- A 200 mA, 29 VDC constant auxiliary output is available; operation is maintained during battery backup

* This product has been approved by the California State Fire Marshal (CSFM) pursuant to Section 13144.1 of the California Health and Safety Code. See CSFM Listing 7165 0026:0378 for allowable values and/or conditions concerning material presented in this document. NYC Fire Dept COA #6151. Additional listings may be applicable; contact your local Simplex product supplier for the latest status. Listings and approvals under Simplex Time Recorder Co. are the property of Tyco Fire Protection Products. Additional listings may be applicable; contact your local Simplex product supplier for the latest status. Listings and approvals under Simplex Time Recorder Co. are the property of Tyco Fire Protection Products.

Introduction

Repeating IDNAC SLCs. Simplex fire alarm control panels with IDNAC SLC outputs provide individual address and control of TrueAlert and TrueAlert ES addressable notification appliances. When an IDNAC SLC reaches the current limit or the distance limit of the source IDNAC SLC, use of 4009 IDNAC Repeaters extends the IDNAC SLC with an additional 3 A of SLC current and up to 139 unit loads of additional supervisory capacity.

With *IDNAC SLCs*, a *constant* 29 VDC source voltage is maintained in alarm, even during battery standby, allowing strobes to operate at higher voltage with lower current and ensuring a consistent current draw and voltage drop margin under both primary power and secondary battery standby. Efficiencies include wiring distances up to 2 to 3 times farther than with conventional notification, or support for more appliances per IDNAC SLC, or use of smaller gauge wiring, or combinations of these benefits, all providing installation and maintenance savings with high assurance that appliances that operate during normal system testing will operate during worst case alarm conditions.

Description

Three wiring configurations are available to provide a variety of system solutions: Class B branch extension, Class A loop extension, and Class A riser to Class B branch extension or Class A loop output.

Description (Continued)

Class B branch input wiring allows T-tapped connections to up to five (5) parallel connected 4009 IDNAC Repeaters. Each Repeater has on-board output terminal connections for up to four (4) output branch circuits, and additional branch circuits can be externally T-tapped as required. (Refer to diagram on page 3 for additional details.)

Class A loop extensions use a single 4009 IDNAC Repeater to extend the current and distance of a single Class A loop allowing the loop distance to be doubled.

The Repeater communicates and repeats bi-directionally allowing Class A loop operation to be maintained in the event of an open circuit. This wiring connection requires use of the 4009-9814 Class A adapter. (Refer to diagram on page 4 for additional details.)

Class A Riser to Class B Branches or Class A Loops. For applications requiring a combination of wiring types, a Class A riser can drive up to five (5) 4009 IDNAC Repeaters with each Repeater capable of driving either single or multiple Class B branch output(s) or a Class A loop output. In this wiring application, the Repeater does not repeat in the Class A riser loop, it is connected as an appliance with Class A in/out wiring. To create a Class A loop output, the Repeater must be equipped with a 4009-9814 Class A Adapter. (Refer to diagram on page 5 for additional details.)

Product Selection

Model*	Cabinet Color	Description
4009-9601(BA)	Platinum	4009 IDNAC Repeater with cabinet; provides a single 3 A IDNAC SLC output, 200 mA auxiliary power output, and battery charger; 120/240 VAC, 50/60 Hz input, auto-select
4009-9602(BA)	Red	

* Add suffix BA to select 4009 IDNAC Repeaters assembled in the USA.

Aftermarket Accessories (installed on-site, select per system requirements)

Model	Description	
4009-9814	Class A Adapter Module, mounts on repeater controller board; required for Class A output	
2975-9813	Platinum semi-flush box trim	1 7/16" (37 mm) wide, four corners and trim pieces for top, bottom, and sides; (will need to be cut to fit 4009 IDNAC Repeater cabinet)
2975-9812	Red semi-flush box trim	

External Accessories (select per system requirements)

Model	Description	Comments
4905-9929	Remote TrueAlert Communications Isolator	Refer to data sheet S4905-0001 for details
4009-9801	External Battery Cabinet for 25 Ah batteries	16 1/4" W x 13 1/2" H x 5 3/4" D (413 mm x 343 mm x 146 mm); refer to data sheet S2081-0006 for details

Battery Selection (select battery size per system requirements; two batteries are required for 24 VDC operation)

Model	Description	Model	Description	
2081-9272	6.2 Ah Battery, 12 VDC	2081-9275	18 Ah Battery, 12 VDC	Requires 4009-9801 External Battery Cabinet
2081-9274	10 Ah Battery, 12 VDC	2081-9287	25 Ah Battery, 12 VDC	
2081-9288	12.7 Ah Battery, 12 VDC			

Wiring Reference, Class B Input with Class B Branch Circuit Outputs

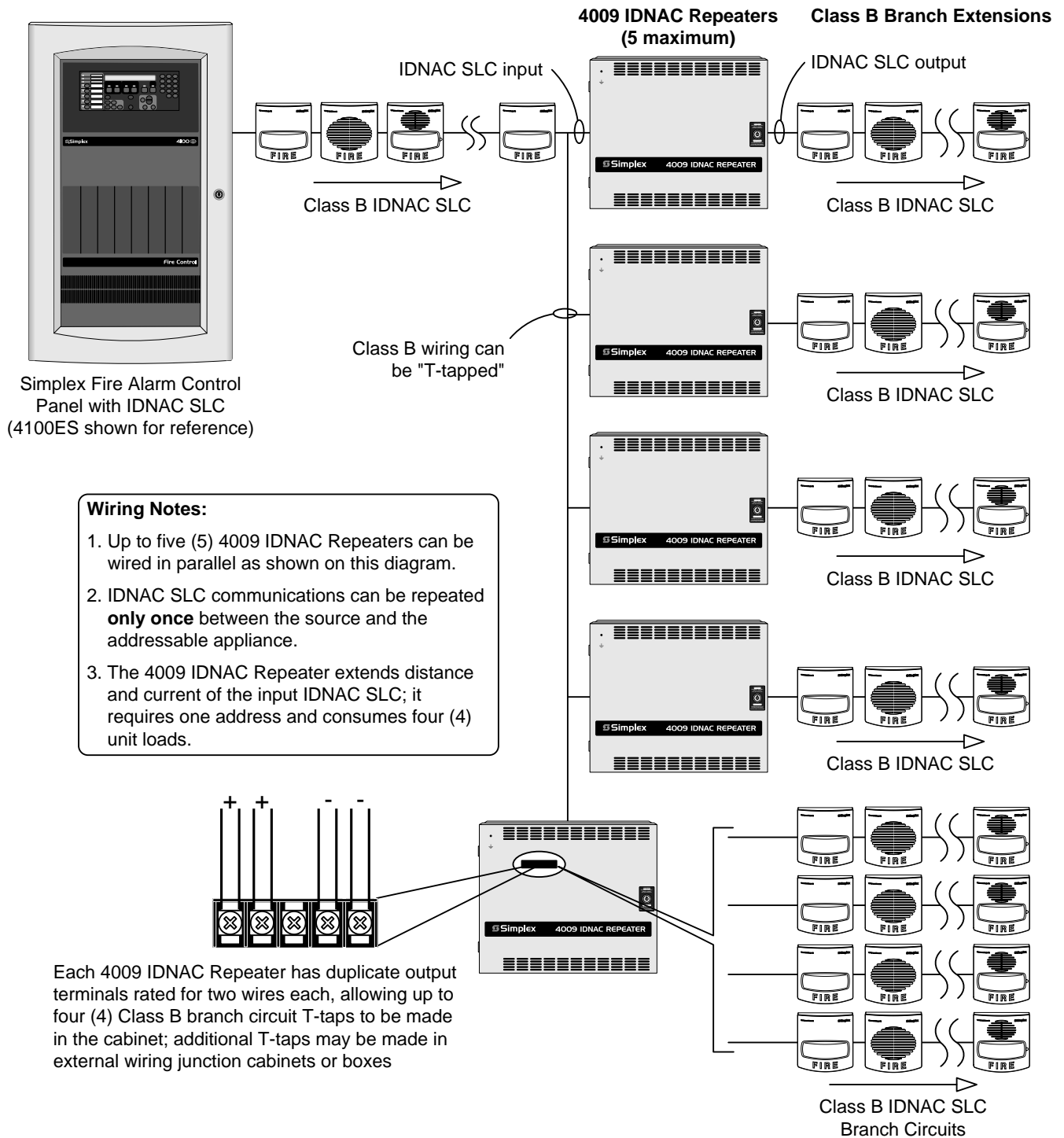

Wiring Notes:

1. Up to five (5) 4009 IDNAC Repeaters can be wired in parallel as shown on this diagram.
2. IDNAC SLC communications can be repeated **only once** between the source and the addressable appliance.
3. The 4009 IDNAC Repeater extends distance and current of the input IDNAC SLC; it requires one address and consumes four (4) unit loads.

Class A IDNAC SLC Loop with 4009 IDNAC Repeater Extending Loop Range and Power

4009 IDNAC Repeater **Requires** optional 4009-9814 Class A Adapter Module **set for Loop mode**

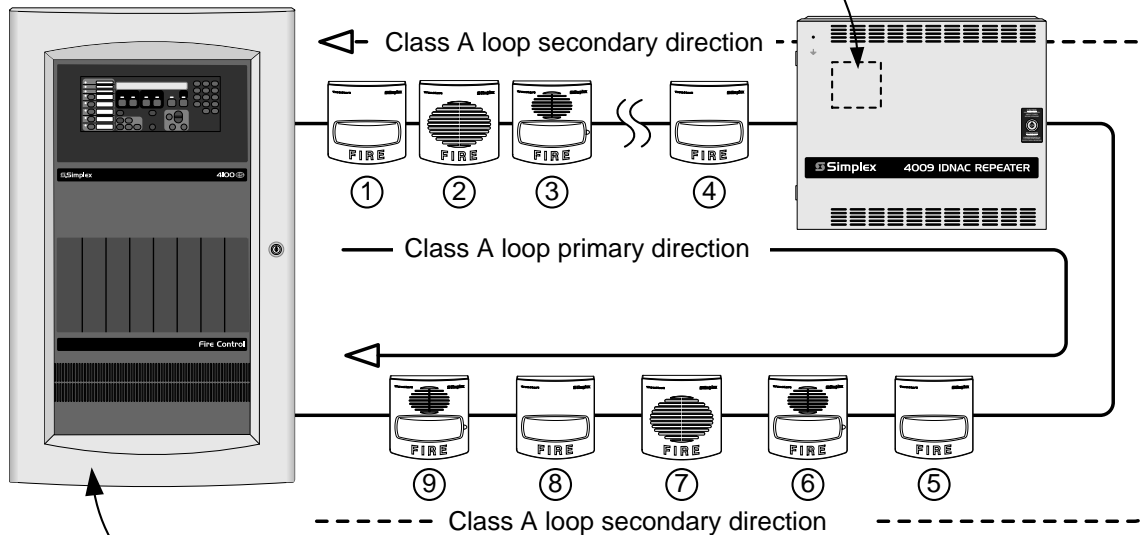

Simplex Fire Alarm Control Panel with IDNAC SLC; **requires** optional Dual Class A IDNAC Isolator (DCAI), refer to individual panel documentation for details (4100ES with EPS shown for reference)

Notes:

1. Only one 4009 IDNAC Repeater can be wired in a Class A loop. (IDNAC SLC communications can be repeated **only once** between the source and the addressable appliance.)
2. The 4009 IDNAC Repeater extends distance and current of the Class A IDNAC SLC loop; it requires one address and consumes four (4) unit loads.
3. Under normal operating conditions (no open circuit wiring), appliances 1 through 4 are powered by the Panel Power Supply and appliances 5 through 9 are powered from the 4009 IDNAC Repeater.
4. Under open circuit conditions, an open circuit in the panel side of the primary path will result in the Panel Power Supply powering appliances 5 through 9 and the 4009 IDNAC Repeater will receive IDNAC SLC input from the return path and then power appliances 1 through 4, or as many as remain connected.

Wiring Reference, Class A Riser Input with Class A Loop and Class B Branch Outputs

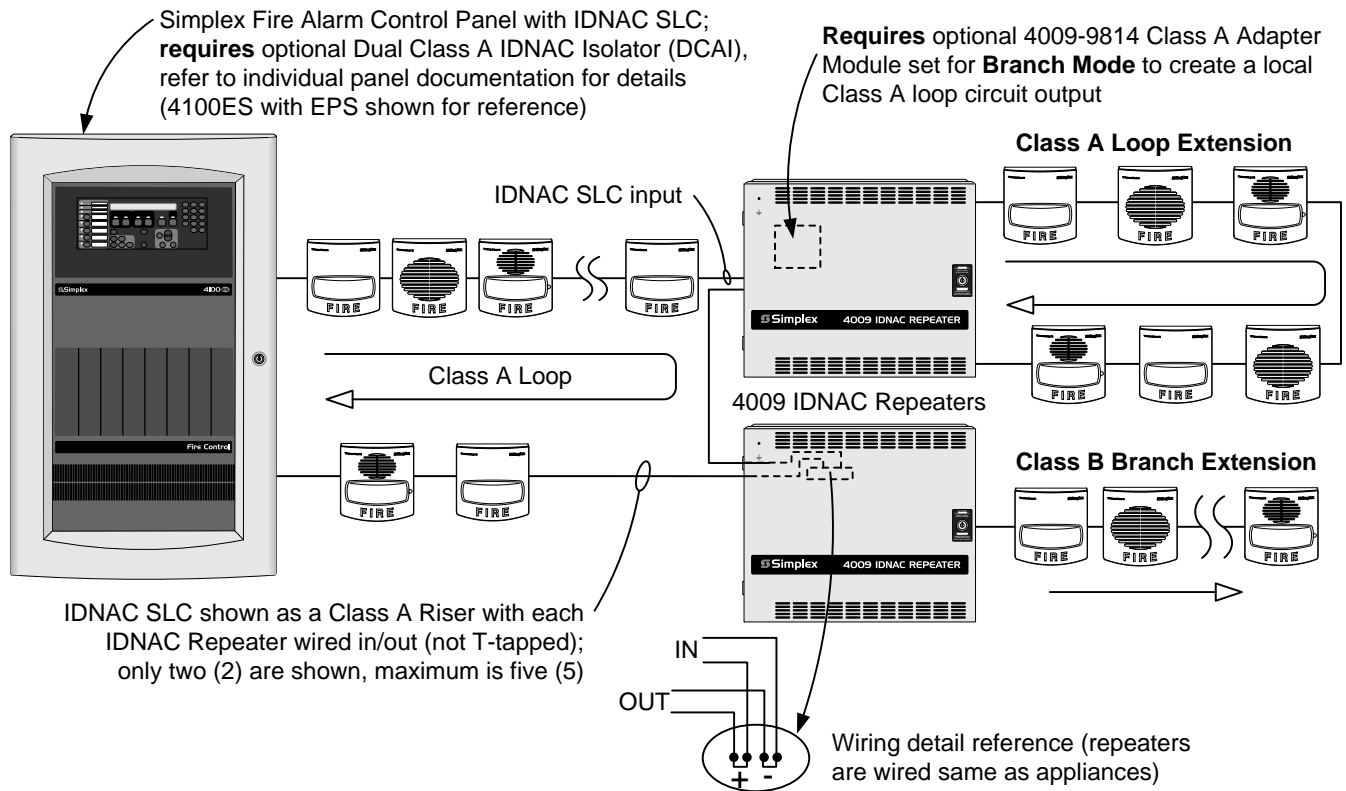

4009 IDNAC Repeater Mounting and Module Placement Reference

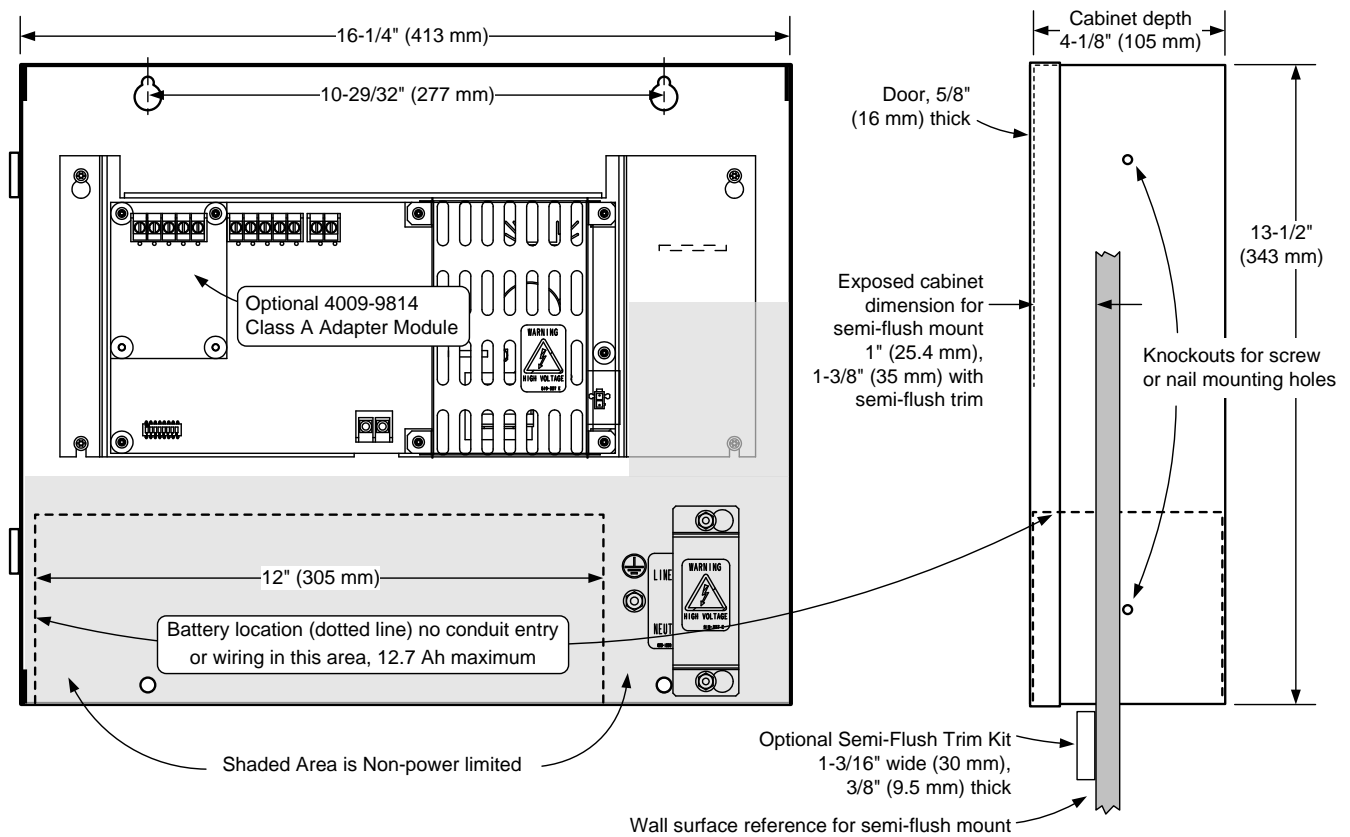

4009 IDNAC Repeater Specifications

Input Ratings

Input Ratings	Voltage Range	120 VAC, 50/60 Hz, or 220/230/240 VAC, 50/60 Hz, +10%, -15%, auto-select
	120 VAC Current	2.5 A
	220/230/240 VAC Current	1.25 A

		Panel	IDNAC Appliances	Auxiliary Load
24 VDC Requirements for Battery Calculations	Standby Currents	70 mA	0.8 mA each	Output current (voltage is from battery)
	Alarm Currents	96 mA	4.5 A maximum with 3 A IDNAC SLC load and 200 mA Auxiliary output load (actual alarm current depends on connected and activated appliances and devices)	1.37 x output current (voltage converter is on when in Alarm)

IDNAC Input Ratings	17 VDC minimum
	1 address, 4 unit loads

Output Ratings

IDNAC SLC Output	3 A maximum @ 29 VDC for Special Application appliances	
Compatible Special Application Appliances	Simplex TrueAlert ES and TrueAlert addressable notification appliances; contact your Simplex product representative for compatible appliances	
IDNAC Repeater Loading and SLC Address Usage	Each repeater uses four unit loads on the EPS it receives power from and supports up to 139 additional unit loads. Most appliances are 1 unit load; Multi-Tone appliances are 2 unit loads; Repeaters and Isolators are 4 unit loads. Refer to individual appliance and device specifications for unit load requirements and rated SLC loading specifications.	
	Each repeater uses one IDNAC SLC device address - the IDNAC Repeater does not increase the IDNAC channel device address capacity. Refer to the Host IDNAC SLC specifications for the device address capacity specifications on the IDNAC channel.	
Auxiliary Output	Current	200 mA maximum
	Voltage	29 VDC nominal with AC present or when Repeater is on battery standby and in Alarm 24 VDC nominal when on battery standby and not in Alarm

IDNAC SLC Wiring Specifications (refer to installation instructions for more information)

Recommended wire type	UTP, unshielded twisted pair
Maximum wire length allowed with "T-Taps" for class B wiring	10,000 ft (3048 m)
Maximum wire length to any appliance	4000 ft (1219 m)
Wiring Connections	Terminal blocks for 18 to 12 AWG

Repeater Status Indicators

Green AC Power LED	On with AC present, off during brownout or no AC condition
Red Communications LED (COMM)	Blinks when Repeater is communicating with the host control panel
Yellow System Status LEDs	4 LEDs provide up to 16 different trouble status indications; an on-board trouble scroll button allows review should multiple troubles occur

4009-9814 Class A Adapter Module Option (required for Class A loop extension or for Class A output)

IDNAC SLC Output Voltage	3 A maximum @ 29 VDC for Special Application appliances
	Two connections, Port A and Port B, function varies by application (loop extension or local loop), Port A and Port B are isolated from each other
Status LEDs	Two yellow trouble LED indicators, one per Port

Environmental and Technical Publications Reference

Operating Temperature	32° to 120° F (0° to 49° C)	
Operating Humidity Range	Up to 93% RH at 90° F (32° C)	
Installation Instructions	4009 IDNAC Repeater	579-1019
	Class A Adapter Module	579-1080

TYCO, SIMPLEX, and the product names listed in this material are marks and/or registered marks. Unauthorized use is strictly prohibited.



Tyco Fire Protection Products • Westminister, MA • 01441-0001 • USA
www.simplex-fire.com

S4009-0004-5 6/2015

© 2014 Tyco Fire Protection Products. All rights reserved. All specifications and other information shown were current as of document revision date and are subject to change without notice.