

Features

Dual port, bi-directional power isolator for use with Simplex® 4007ES, 4010ES, 4100ES, and 4100U Series fire alarm control panels:

- Either port can serve as an input or output, ports are automatically separated when a power wiring short circuit or a low voltage condition occurs
- Isolation can also be activated from the control panel for system diagnostics
- For use with fire alarm control panel system power, rated for up to 2 A @ 32 VDC
- Isolators communicate their location specific address and status, and accept control via IDNet communications
- Small size fits into 4” square electrical box and allows convenient mounting where protection is required
- Visible LED flashes to indicate communications; optional covers are available to view LED after installation

Earth fault isolation reduces time to fix wiring problems:

- Built-in control panel diagnostics can activate the addressable power isolator, assisting in locating earth fault conditions – the most common installation wiring problem

For Class B or Class A power wiring:

- Power is monitored from either port
- Two Isolators can be connected to produce Class A power wiring that can optimize operation by maintaining connection with devices outside of the isolated wiring section

UL listed to Standard 864

Description

Short Circuit Isolation. Under normal conditions, the 4090-9117 Addressable Power Isolator provides continuity between ports. In the event of a short circuit, or if requested from the control panel, the isolator opens a two-pole electronic switch, isolating both power circuit conductors.

Operation. Isolators power-up in isolation mode and are directed to connect by the control panel. If the output wiring is acceptable, the isolator will connect to the rest of the circuit. If the output wiring is shorted, the isolator remains isolated.

Status Tracking. The isolator reports to the panel when it is in isolation mode and the extent of shorted wiring is available at the panel by identifying non-communicating device addresses. [Isolators are assigned sequentially to low number addresses to expedite Signaling Line Circuit (SLC) power-up. Refer to Installation Instructions 574-873 for additional information.]

Earth Faults. During system installation, earth faults frequently occur. Finding these faults normally requires extensive wiring disconnection. With the Addressable Power Isolator, earth faults on fire alarm system power wiring can be more quickly located to expedite repair.

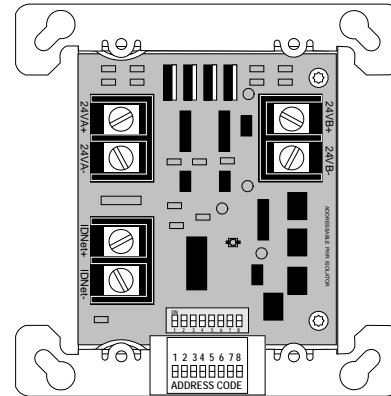

4090-9117 Addressable Power Isolator with IDNet Communications Control (shown approximately 1/2 size)

Product Selection

Model	Description	
4090-9117	Addressable Power Isolator	
4090-9801	For semi-flush mounted box	Optional trim plate with LED viewing window, includes mounting screws; galvanized steel
4090-9802	For surface mounted box	

Specifications

Electrical	
Current Rating	2 A maximum @ 32 VDC maximum
Input Power	10 mA maximum @ 24 VDC, system power
Communications	IDNet communications, 1 address, one unit load
Wire Connections	Screw terminals for input and output wiring, 18 to 14 AWG (0.82 mm ² to 2.08 mm ²), two wires/terminal; up to 12 AWG (3.31 mm ²), one wire/terminal

Wiring Reference

Power Wiring	Refer to individual devices for wiring distances Compatible with 2081-9028 Circuit Protector
IDNet Communication s Wiring Reference	Up to 2500 ft (762 m) from fire alarm control Up to 10,000 ft (3048 m) total wiring distance (including T-Taps) Compatible with Simplex 2081-9044 Overvoltage Protectors

Mechanical

Dimensions	4-1/8" H x 4-1/8" W x 1-3/8" D (105 mm x 105 mm x 35 mm)
Temperature	32° to 120° F (0° to 49° C) indoor operation only
Humidity Range	10 to 90% RH at 90° F (32° C)

* This product has been approved by the California State Fire Marshal (CSFM) pursuant to Section 13144.1 of the California Health and Safety Code. See CSFM Listing 7300-0026:252 for allowable values and/or conditions concerning material presented in this document. Additional listings may be applicable; contact your local Simplex product supplier for the latest status. Listings and approvals under Simplex Time Recorder Co. are the property of Tyco Fire Protection Products.

Power Isolator Multi-Floor Example 1

Short Circuit Isolation. The one-line diagram on this page shows a multiple floor example with Class B IDNet communications and conventional Class B power wiring. Each floor's wiring starts at an isolator. If any floor wiring beyond the isolator experiences a short circuit, each floor will be individually separated from the next, preventing the short circuit from disabling the entire wiring run.

Earth Fault Isolation. In the event of an earth wiring fault, each floor's power wiring can be individually isolated using control panel diagnostics. This narrows the search area by disconnecting the isolated wiring section and can result in decreasing the time required to locate and correct the earth fault.

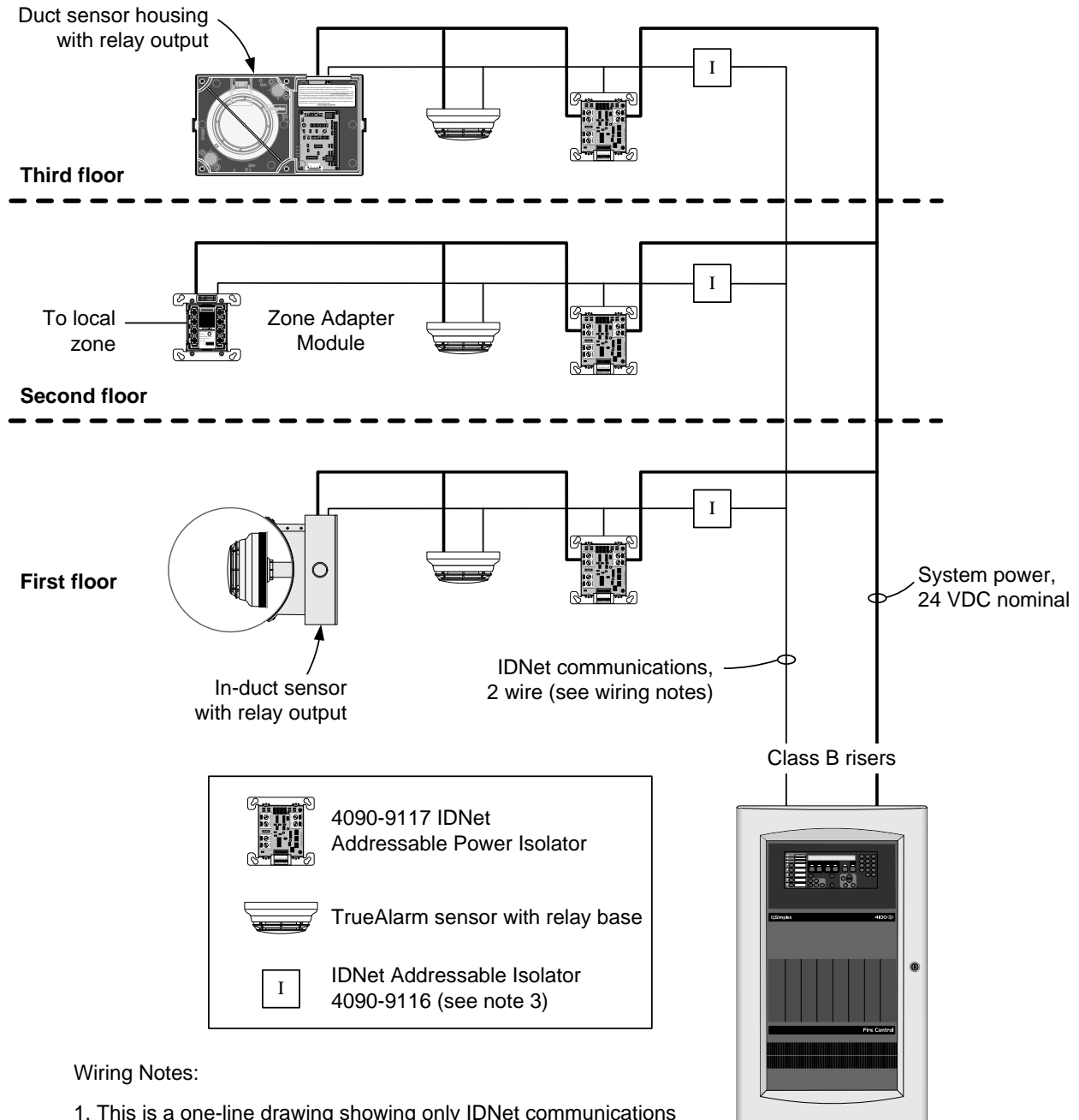

Wiring Notes:

1. This is a one-line drawing showing only IDNet communications and power wiring.
2. Operation of the 4090-9117 Addressable IDNet Power Isolator requires connection to a 4100ES, 4010ES, 4007ES, or 4100U IDNet communications channel.
3. IDNet isolators are shown for typical reference but are not required.

Simplex 4100ES Series
Fire Control Panel
(shown for reference)

Power Isolator Multi-Floor Example 2

Class A Wiring. The illustration below is a modification of Example 1. Each floor wiring loop connects to the next floor in a Class A connection. From the last device, the wiring returns to the panel providing a secondary path that is monitored for loop integrity. Class A power wiring is available from a 4100ES, 4010ES, 4007ES, or 4100U Fire Control Panel programmed for this application using two 4090-9117 Power Isolators mounted close-nippled at the panel.

Diagnostic Assistance. It is recommended that for Class A wiring, isolators be located as the first and last devices in the loop (as shown below). With the resulting wiring isolation flexibility, locating earth wiring faults can be made easier

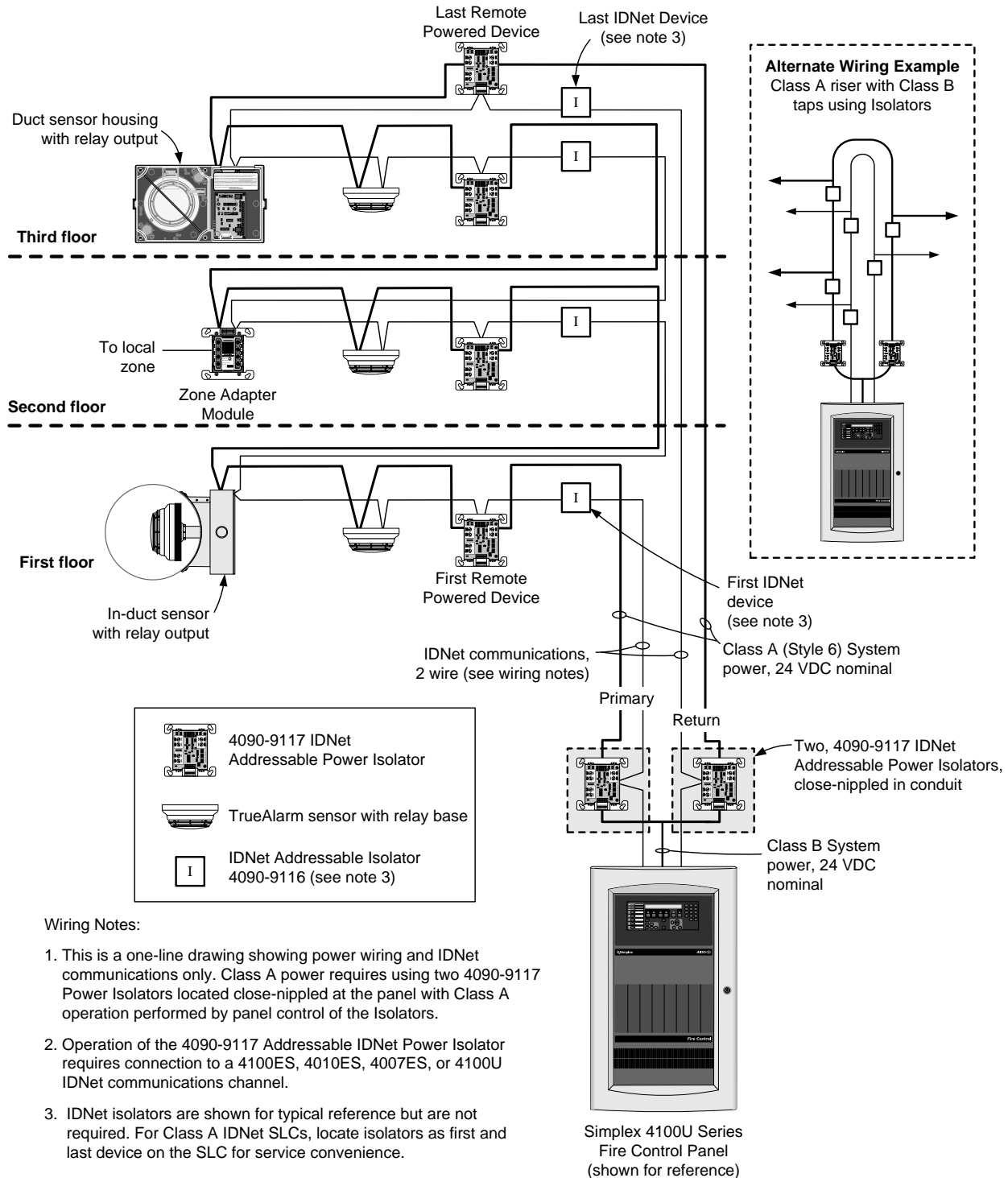

Mounting Information

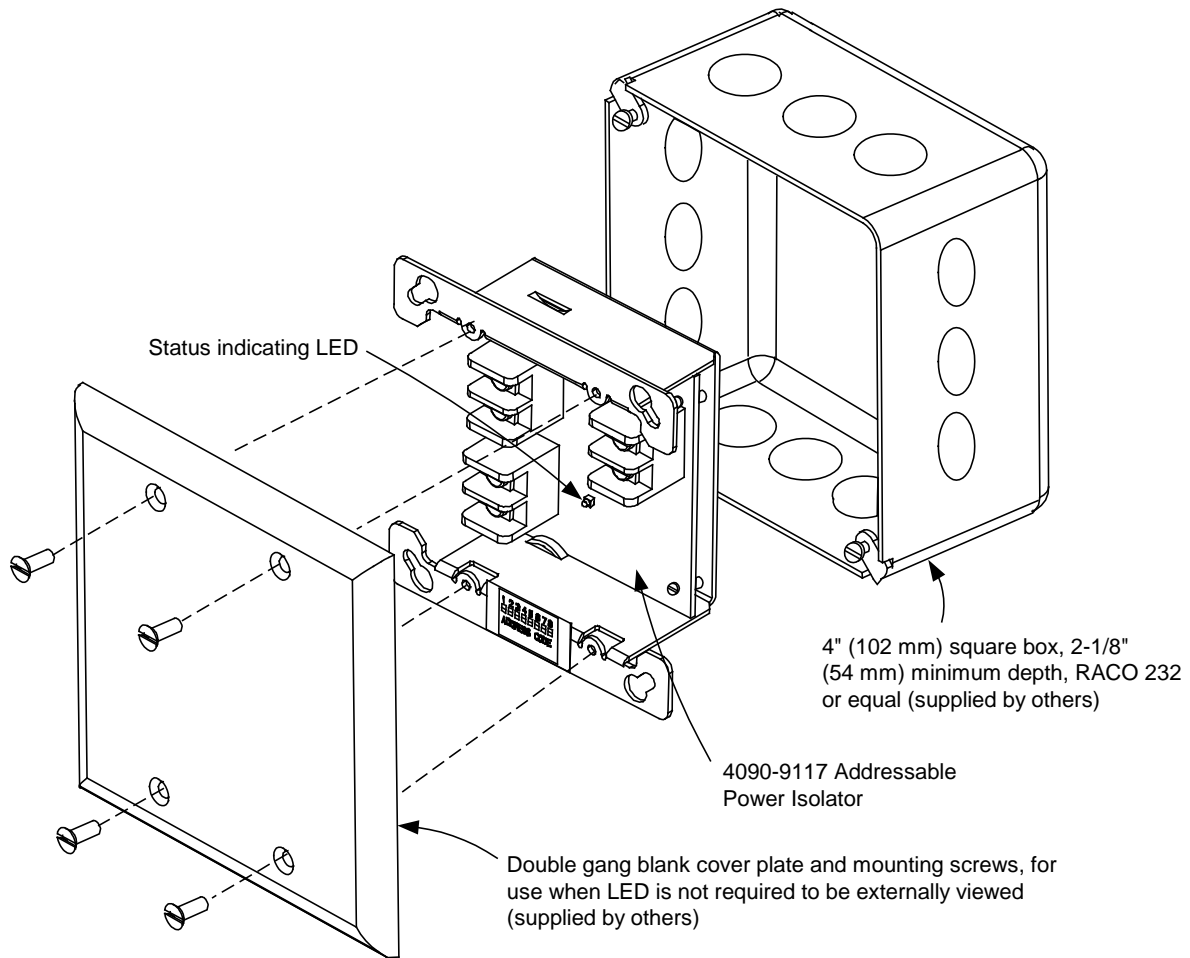

Mounting Reference, Double Gang Blank Cover Plate

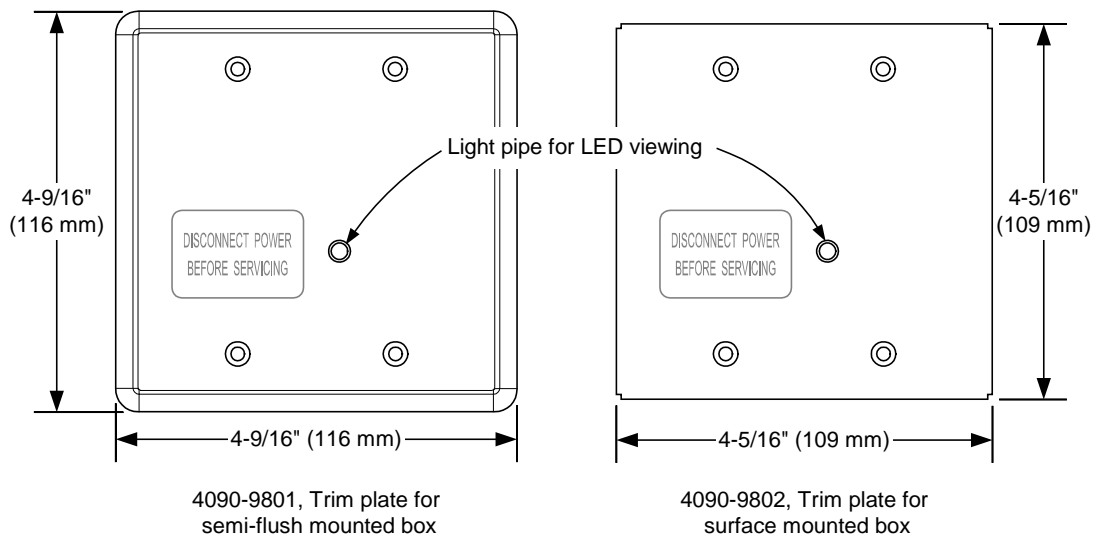

Optional Trim Plates for Visible LED

TYCO, SIMPLEX, and the product names listed in this material are marks and/or registered marks. Unauthorized use is strictly prohibited.



Tyco Fire Protection Products • Westminister, MA • 01441-0001 • USA
www.simplex-fire.com

S4090-0006-7 11/2014

© 2014 Tyco Fire Protection Products. All rights reserved. All specifications and other information shown were current as of document revision date and are subject to change without notice.