

Features

Accurate thermal detection for protection of property**

UL listed to Standard 521

Fixed temperature operation is suitable for most applications:

- Thermistor based design is inherently rate compensated due to minimal thermal lag
- Available for 135° F (57° C) or 200° F (93° C)
- UL spacing distance is 60 ft

Available with rate-of-rise temperature detection:

- Dual thermistor rate-of-rise operation
- For use where anticipated ambient temperature changes are less than 6° F/minute
- UL spacing distance is 70 ft

Epoxy encapsulated electronic design provides:

- Operation for ceiling or wall mounting
- Easily tested, self-restoring operation with repeatable accuracy
- Alarm indicating LED located on detector
- Current limited alarm that is compatible with two-wire initiating device circuits (IDCs)

Direct connecting design:

- Wiring attaches directly to detector terminals
- Detector mounts onto mechanical adapter plate (supplied)

Description

Accurate Electronic Design. Simplex® electronic heat detectors use a fast response, thermistor based design to provide temperature sensing that quickly, accurately, and consistently identifies when fixed temperatures are exceeded. The fixed temperature sensing thermistor readily tracks the local ambient temperature. This eliminates the time required to melt a lead pellet or heat a bimetallic element as occurs in mechanical heat detector designs and provides the required heat detection for most applications.

Rate-of-rise detection is determined by comparing two thermistor responses. By combining accurate thermistors with proper physical placement, this patented rate-of-rise detection design achieves a high level of performance not normally available with mechanical detection.

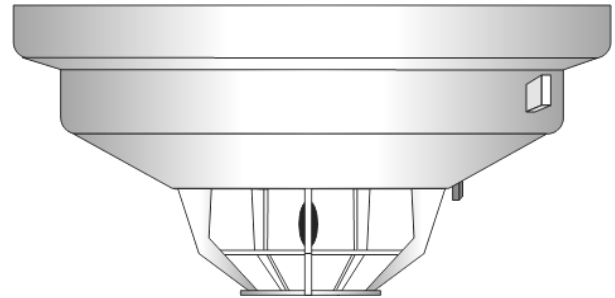

Electronic Direct Connect Heat Detector

Specifications

Voltage Range	15 to 32 VDC, filtered DC with 30% maximum ripple
Standby Current	80 µA nominal
Alarm Current	Up to 100 mA maximum, exact current is determined by alarm current limiting of connected IDC
Rate-of-Rise Operation	Meets FM requirements for operation between 15° and 25° F/min (8.33° and 13.88° C/min)
Humidity Range	10% to 95% RH, not intended for outdoor applications
Storage Temperature	0° to 140° F (-18° C to 60° C)
Color	Off-white
Dimensions	See diagram on page 2
Ambient Temperature Operating Range	
135° F Models	32° to 100° F (0° to 38° C)
200° F Models	32° to 150° F (0° to 68° C)

* This product has been approved by the California State Fire Marshal (CSFM) pursuant to Section 13144.1 of the California Health and Safety Code. See CSFM Listing 7270-0026:200 for allowable values and/or conditions concerning material presented in this document. Accepted for use – City of New York Department of Buildings – MEA35-93E. This product was not ULC listed as of document revision date. Additional listings may be applicable, contact your local Simplex product supplier for the latest status. Listings and approvals under Simplex Time Recorder Co. are the property of Tyco Fire Protection Products.

**** WARNING: In most fires, hazardous levels of smoke and toxic gas can build up before a heat detection device would initiate an alarm. In cases where Life Safety is a factor, the use of smoke detection is highly recommended.**

Applications Reference

Heat detectors are used where property protection is desired and where life safety protection is not required or is performed by other equipment. Typical heat detector applications are satisfied by use of these fixed temperature electronic detectors.

The addition of rate-of-rise operation provides two forms of heat detection for use where temperature fluctuations are controlled and are less than 6° F/min (3.33° C/min). Where temperatures may fluctuate more quickly, use fixed temperature detection.

Fixed Temperature Guidelines

135° F (57° C) fixed temperature detectors are for normal temperatures that do not exceed 100° F (38° C).

200° F (93° C) fixed temperature detectors are for normal temperatures that exceed 100° F (38° C) but are less than 150° F (66° C).

Alarm Indicating LED Operation

The heat detector LED turns ON continuously when in alarm. During normal conditions the LED is OFF.

Product Selection

Model	Rating	Type	UL Maximum Spacing	FM Maximum Spacing
4098-9401	135° F (57° C)	Fixed temperature	60 ft x 60 ft (18.3 m x 18.3 m)	15 ft X 15 ft (4.5 m x 4.5 m)
4098-9402		Fixed with rate-of-rise	70 ft x 70 ft (21.3 m x 21.3 m)	30 ft X 30 ft (9.1 m x 9.1 m)
4098-9403	200° F (93° C)	Fixed temperature	60 ft x 60 ft (18.3 m x 18.3 m)	15 ft X 15 ft (4.5 m x 4.5 m)
4098-9404		Fixed with rate-of-rise	70 ft x 70 ft (21.3 m x 21.3 m)	30 ft X 30 ft (9.1 m x 9.1 m)

Installation Reference

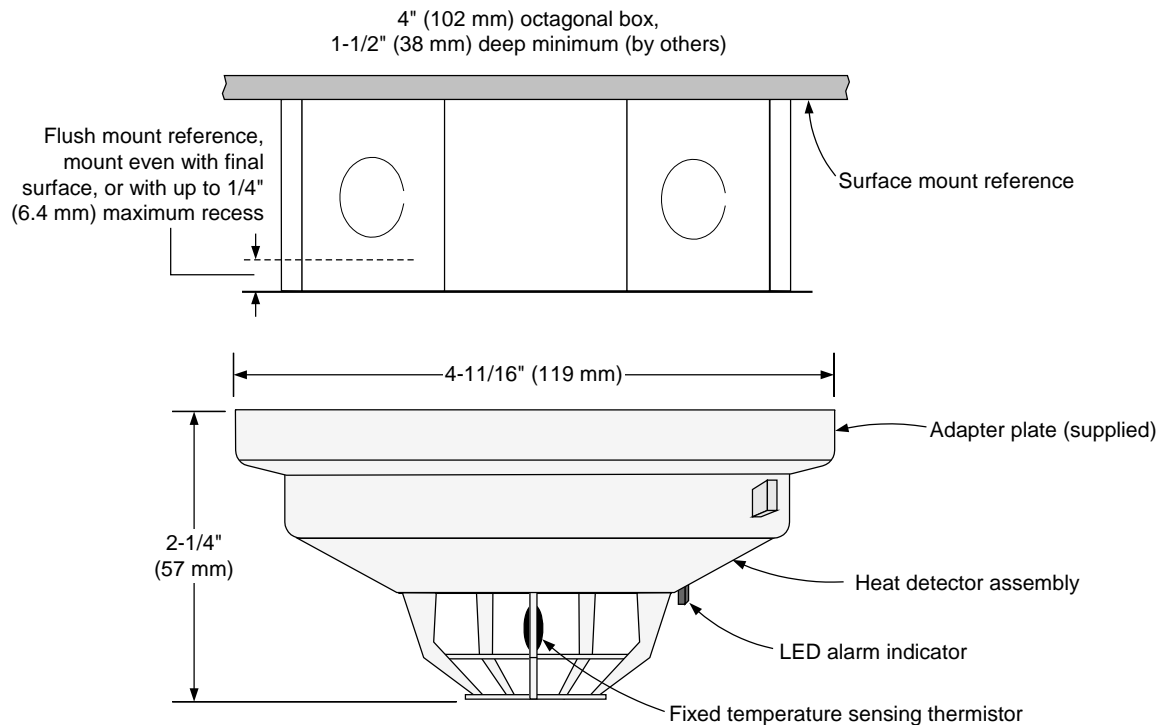

NOTE: Refer to Installation Instructions 574-686 for additional information.

Applications Reference

The following table provides a reference for the maximum rectangular area covered for detectors rated with the given spacing. For additional information, including consideration of ceiling height, refer to NFPA 72, the *National Fire Alarm Code*.

Maximum Rectangular Area Dimensions For Single Detector Coverage

15 ft Rated Spacing (4.5 m)	30 ft Rated Spacing (9.1 m)	60 ft Rated Spacing (18.3 m)	70 ft Rated Spacing (21.3 m)
15 ft x 15 ft (4.5 m x 4.5 m)	30 ft x 30 ft (9.1 m x 9.1 m)	60 ft x 60 ft (18.3 m x 18.3 m)	70 ft x 70 ft (21.3 m x 21.3 m)
10 ft x 18.7 ft (3 m x 5.7 m)	25 ft x 34.2 ft (7.6 m x 10.4 m)	55 ft x 64.6 ft (16.7 m x 19.7 m)	65 ft x 74.6 ft (19.8 m x 22.7 m)
5 ft x 20.6 ft (1.5 m x 6.2 m)	20 ft x 37.4 ft (6.1 m x 11.4 m)	50 ft x 68.5 ft (15.2 m x 20.8 m)	60 ft x 78.7 ft (18.3 m x 24 m)
1 ft x 21.19 ft (0.3 m x 6.4 m)	15 ft x 39.7 ft (4.5 m x 12.1 m)	45 ft x 72 ft (13.7 m x 21.9 m)	55 ft x 82.3 ft (16.7 m x 25 m)
	10 ft x 41.2 ft (3.5 m x 12.5 m)	40 ft x 74.8 ft (12.2 m x 22.8 m)	50 ft x 85.4 ft (15.2 m x 26 m)
	5 ft x 42.1 ft (1.5 m x 12.8 m)	35 ft x 77.3 ft (10.6 m x 23.5 m)	45 ft x 88.1 ft (13.7 m x 26.8 m)
	1 ft x 42.4 ft (0.3 m x 12.9 m)	30 ft x 79.3 ft (9.1 m x 24.1 m)	40 ft x 90.5 ft (12.2 m x 27.5 m)
		25 ft x 81 ft (7.6 m x 24.7 m)	35 ft x 92.6 ft (10.6 m x 28.2 m)
		20 ft x 82.4 ft (6.1 m x 25.1 m)	30 ft x 94.3 ft (9.1 m x 28.7 m)
		15 ft x 83.5 ft (4.5 m x 25.4 m)	25 ft x 95.7 ft (7.6 m x 29.1 m)
		10 ft x 84.2 ft (3.05 m x 25.6 m)	20 ft x 96.9 ft (6.1 m x 29.5 m)
		5 ft x 84.7 ft (1.5 m x 25.8)	15 ft x 97.8 ft (4.5 m x 29.8 m)
		1 ft x 84.85 ft (0.3 m x 25.8 m)	10 ft x 98.4 ft (3.05 m x 30 m)
			5 ft x 98.8 ft (1.5 m x 30.1 m)
			1 ft x 99 ft (0.3 m x 30.2 m)

TYCO, SIMPLEX, and the product names listed in this material are marks and/or registered marks. Unauthorized use is strictly prohibited. NFPA 72 and National Fire Alarm and Signaling Code are registered trademarks of the National Fire Protection Association (NFPA).



Tyco Fire Protection Products • Westminister, MA • 01441-0001 • USA
www.simplex-fire.com

S4098-0007-13 1/2015

© 2015 Tyco Fire Protection Products. All rights reserved. All specifications and other information shown were current as of document revision date and are subject to change without notice.