

Features

Isolator base for TrueAlarm analog sensors using IDNet addressable communications:

- Compatible with Simplex® 4007ES, 4008, 4010, 4010ES, 4100ES, or 4100U Series fire alarm control panel IDNet Signaling Line Circuits (SLCs) providing: IDNet, IDNet+, IDNet 1+, IDNet 2, or IDNet 2+2 output loops (see additional information on pages 2 and 3)
- Can be installed up to 250 total allowing isolation directly to the device level (200 total with 4008)
- Operation is for ceiling or wall mounting
- Base mounted LED indicates sensor status
- Designed for EMI compatibility
- UL listed to Standard 268; ULC listed to Standard S529

Short circuit wiring isolation:

- Input is automatically separated from output when an output communications short circuit occurs

Earth fault isolation reduces time to fix wiring problems:

- Built-in control panel diagnostics assist in locating earth fault conditions – the most common installation wiring problem

Isolator base 4098-9793 is compatible with:

- Photoelectric sensor model 4098-9714
- Heat sensor model 4098-9733
- Multi-sensor model 4098-9754

For Class B or Class A wiring:

- Communications are received from either input or output allowing bases with Class A wiring to isolate short circuits while still operating their sensors

Description

TrueAlarm Sensing and IDNet communication isolation. The 4098-9793 IDNet Communications Isolator Base provides Simplex TrueAlarm analog sensor operation and also provides IDNet communications isolation to improve installation convenience and increase system integrity. Isolation is automatically activated at the base when an output short circuit is detected and isolation can also be selected per base manually from the control panel to assist with troubleshooting wiring problems.

Operation. Isolator bases power-up in isolation mode and are directed to connect by the control panel. If the output wiring is acceptable, the isolator base will connect to the rest of the circuit. If the output wiring is shorted, the isolator remains isolated.

* This product is listed by the California State Fire Marshal (CSFM) pursuant to Section 13144.1 of the California Health and Safety Code. See CSFM Listing 7300-0026:0217 for allowable values and/or conditions concerning material presented in this document. Accepted for use – City of New York Department of Buildings – MEA35-93E. Additional listings may be applicable; contact your local Simplex product supplier for the latest status. Listings and approvals under Simplex Time Recorder Co. are the property of Tyco Fire Protection Products.

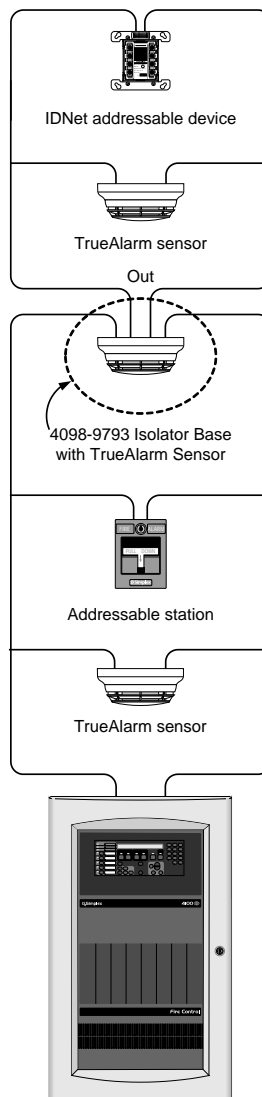

IDNet Channel with a Single 4098-9793 Isolator Base (4100ES Fire Alarm Control Panel shown for reference)

Description (Continued)

Status Tracking. The isolator reports back to the panel when it is in isolator mode and the extent of shorted wiring is reported back to the panel by identifying device addresses that are not communicating. [Isolators are assigned sequentially to low number addresses to expedite Signaling Line Circuit (SLC) power-up. Refer to Installation Instructions 574-709 and 574-707 for additional information.]

Earth Faults. During installation, earth faults often occur and finding these faults normally requires extensive wiring disconnection. With the 4098-9793 isolator base, wiring suspected to have earth faults can be isolated to assist in their discovery and repair.

Multi-Floor Isolator Example 1

The one-line diagram on this page shows a multiple floor example with Class B IDNet communications for each floor starting at an isolator base. If any floor wiring beyond the isolator base should experience a short circuit, each floor can be individually separated from the next, preventing the short circuit from disabling the entire IDNet communications wiring.

In the event of an earth connection, each floor can be individually isolated using the built-in control panel diagnostics. With individual floor control, the earth fault can be isolated to the floor level to narrow the search area.

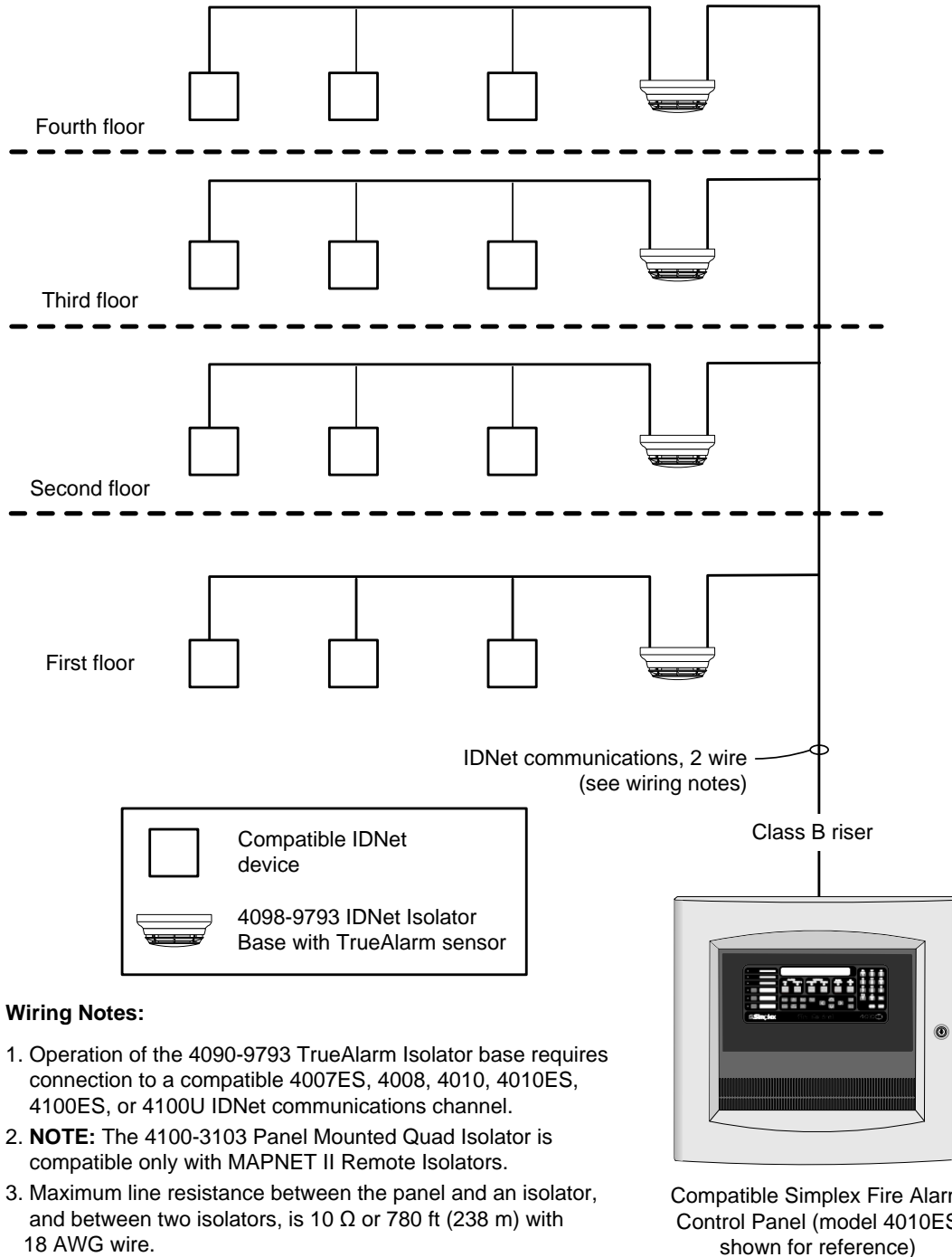

Wiring Notes:

1. Operation of the 4090-9793 TrueAlarm Isolator base requires connection to a compatible 4007ES, 4008, 4010, 4010ES, 4100ES, or 4100U IDNet communications channel.
2. **NOTE:** The 4100-3103 Panel Mounted Quad Isolator is compatible only with MAPNET II Remote Isolators.
3. Maximum line resistance between the panel and an isolator, and between two isolators, is 10 Ω or 780 ft (238 m) with 18 AWG wire.
4. This is a one-line drawing showing only IDNet communications wiring.
5. Some IDNet devices require additional wiring for power. Refer to specific devices for details.

Multi-Floor Isolator Example 2

The illustration below is a modification of Example 1. Wiring for each floor has an additional isolator base and the IDNet circuit is wired as a Class A connection. With the addition of these isolator bases, wiring between floors can be better protected in the event of a short circuit. Also, in the event of an earth connection, the additional isolator base per floor allows earth fault isolation to be achieved with better precision.

Diagnostic Assistance. Communications from an IDNet 2, IDNet 2+2, or IDNet+ output provide individual short circuit isolation and allow individual output control to provide assistance in locating wiring faults.

Note: When wiring Class A IDNet communications provided by IDNet or IDNet 1+ outputs, locate isolators as the first and last devices in the loop, close to the panel, to provide loop short circuit isolation operation (as shown below).

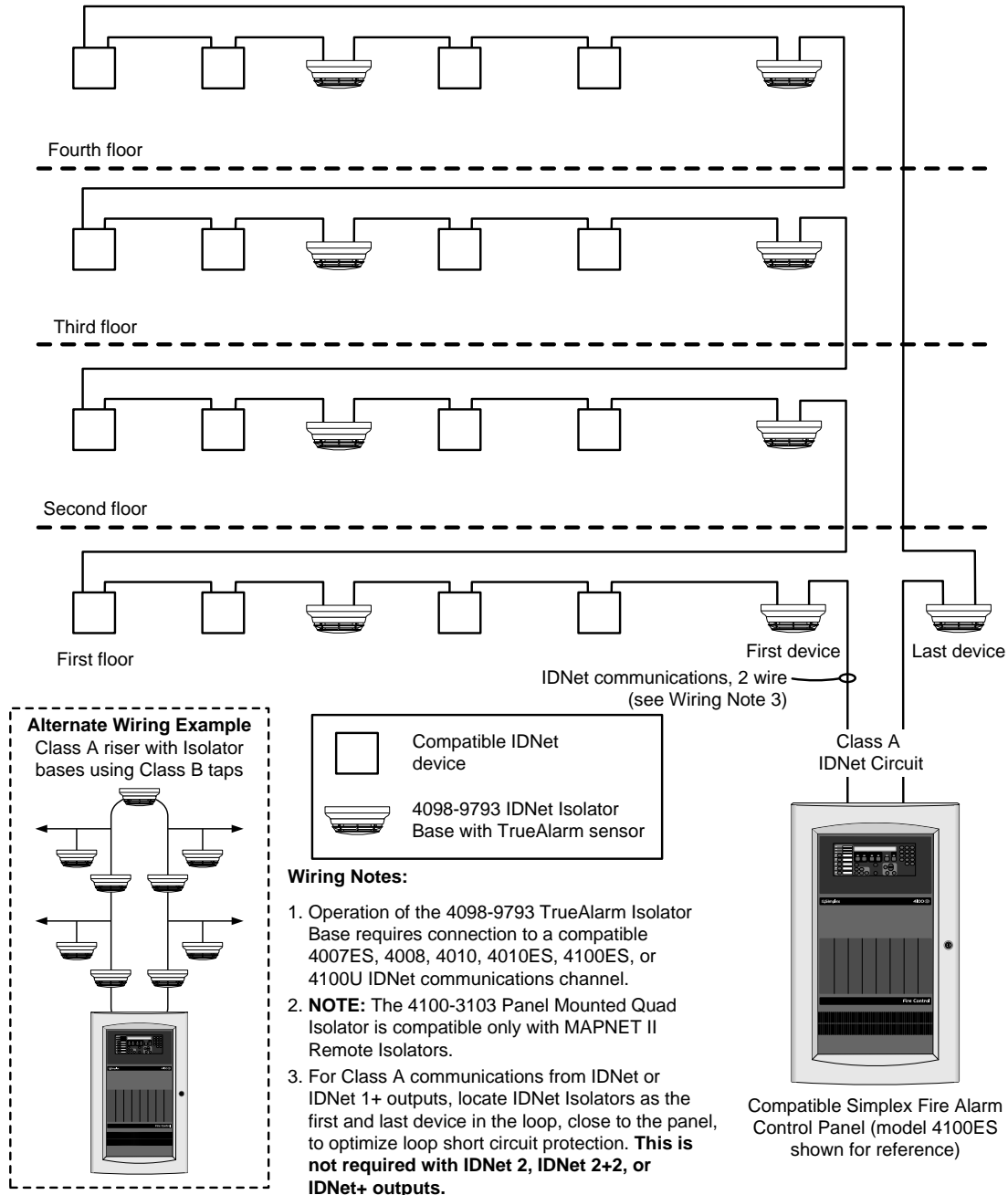

Specifications (for additional information refer to Installation Instructions 574-709 and 574-707)

Power and Communications	IDNet communications, one address per base	
Distance Specification	Maximum line resistance between panel and isolator, or between isolators is 10 ohms; [18 AWG (0.82 mm ²) = 780 ft (238 m)]	
IDNet Connections	Screw terminals for in/out wiring, 18 to 14 AWG (0.82 to 2.08 mm ²)	
UL Listed Temperature Range	32° F to 100° F (0° C to 38° C)	
Operating Temperature Range	15° F to 122° F (-9° C to 50° C)	
Storage Temperature Range	0° F to 140° F (-18° C to 60° C)	
Humidity Range	10 to 95% RH, from 32° F to 122° F (0° C to 50° C)	
Housing Color	Frost White (4098-9793) or Black (4098-9777)	
Sensor Compatibility (sensors are ordered separately)	Product	Data Sheet
	4098-9714, Photoelectric Sensor	S4098-0019
	4098-9774, Photoelectric Sensor	
	4098-9733, Heat Sensor	
	4098-9778, Heat Sensor	
	4098-9754, TrueSense Multi-Sensor	S4098-0024
4098-9779, TrueSense Multi-Sensor		
Additional Isolator Products	4090-9116, Remote IDNet Isolator Module (not available with 4010 control panels)	S4090-0005
	4090-9117, 24 V Addressable Power Isolator (not available with 4008 or 4010 control panels)	S4090-0006

Mounting Information

Electrical Box Requirements:

4" octagonal or 4" square, 1-1/2" deep;
single gang, 2" deep (by others)

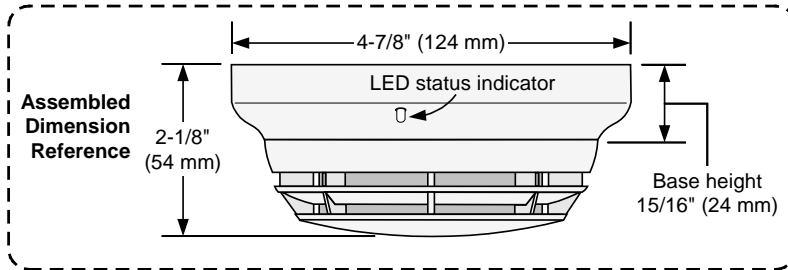
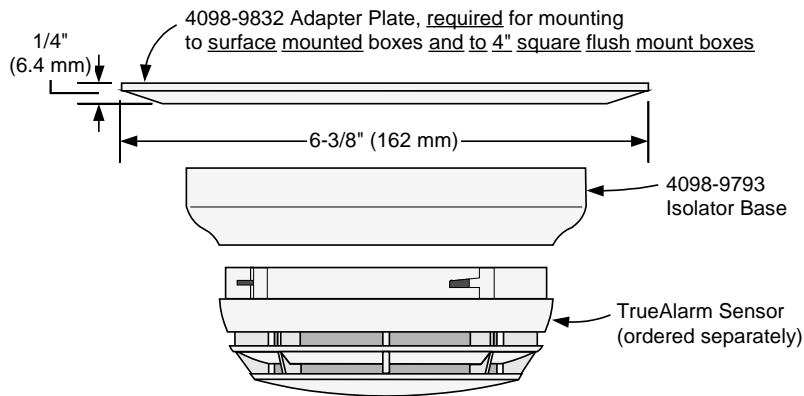
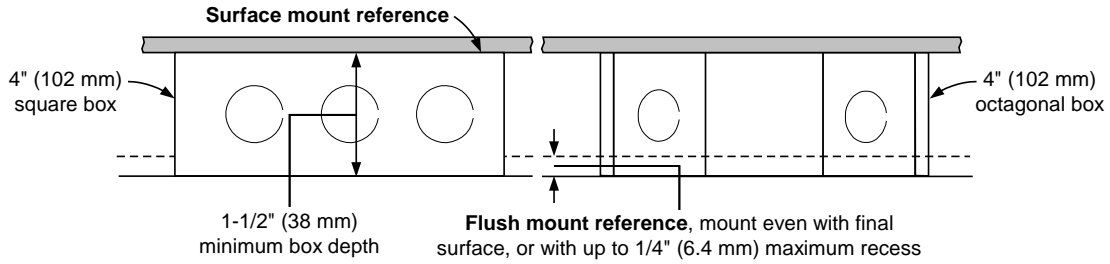

TYCO, SIMPLEX, and the product names listed in this material are marks and/or registered marks. Unauthorized use is strictly prohibited.



Tyco Fire Protection Products • Westminster, MA • 01441-0001 • USA
www.simplex-fire.com

S4098-0025-9 10/2016

© 2016 Tyco Fire Protection Products. All rights reserved. All specifications and other information shown were current as of document revision date and are subject to change without notice.