

#### Features

##### Install the model 4098-9714 TrueAlarm analog photoelectric sensor directly inside air ducts\*\* :

- Accommodates duct airflow from 0 to 4000 ft/min (0 to 1220 m/min), providing HVAC duct smoke sensing where sampling tube designs are not appropriate (refer to specifications on page 4 for more information)
- For applications with controlled dust and humidity
- Standard models are for rectangular ducts from 6" (152 mm) square to 36" (914 mm) square
- Optional adapters allow use with round ducts of 6", 8" (203 mm), 10" (254 mm) or 12" (305 mm) in diameter
- TrueAlarm analog communications can be either IDNet or MAPNET II format
- Model 4098-9714 sensor is required and ordered separately

##### Red alarm LED indicator in housing:

- Visible through transparent housing cover
- Pulsing indicates power-on, steady on indicates alarm or trouble as indicated at the fire alarm control panel

##### Model 4098-9750 provides two-wire operation (no relay output)

##### Model 4098-9751 provides a local relay:

- Relay operation is programmable from fire alarm control panel and is rated: 1 A @ 28 VDC, power limited; or 1/2 A @ 120 VAC, non-power limited
- 24 VDC power is supplied by fire alarm system (4-wire operation)

##### Options:

- Adapters for 6", 8", 10" or 12" round ducts
- Remote Test Station (2098-9806)
- Remote LED Alarm Indicator (2098-9808)

##### UL listed to Standard 268A

\*\* Please note that smoke detection in air ducts is intended to notify of the presence of smoke *in the duct*. It is not intended to, and will not, replace smoke detection requirements for open areas or other non-duct applications.

\* This product has been approved by the California State Fire Marshal (CSFM) pursuant to Section 13144.1 of the California Health and Safety Code. See CSFM Listing 3240-0026:220 for allowable values and/or conditions concerning material presented in this document. ULC listed models are designated with a "C" suffix such as 4098-9750C. Accepted for use - City of New York Department of Buildings - MEA35-93E. Additional listings may be applicable; contact your local Simplex product supplier for the latest status. Listings and approvals under Simplex Time Recorder Co. are the property of Tyco Fire Protection Products.

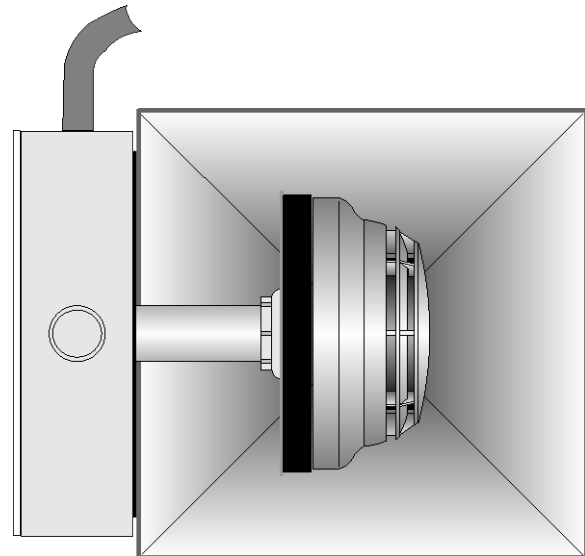

In-Duct Housing with 4098-9714 Sensor  
(mounted in 8" square duct for reference)

#### Description

**HVAC air ducts** in buildings supply fresh air and exhaust stale air. Depending on the overall fire detection requirements, smoke detection may be required in the air ducts. For applications where sampling tube type duct detection is not appropriate due to low air velocity or small duct size, Simplex® model 4098-9750 and 4098-9751 housings can be used to install the Simplex model 4098-9714 TrueAlarm analog sensor directly in the duct. (Refer to data sheet S4098-0030 for smoke sensor housings with sampling tubes.)

**Application.** These housings mount a spot-type smoke sensor directly into the duct airflow. Proper application requires controlled dust and humidity.

**Please note** that in the event of loss of duct airflow, the 4098-9714 sensor will sense smoke IF the smoke reaches the sensor. However, with no duct airflow, smoke may not reach the sensor depending on the location of the smoke source relative to the sensor.

**TrueAlarm Operation.** Placing a 4098-9714 sensor in an air duct provides the high reliability performance of TrueAlarm analog sensing featuring: programmable sensitivity, consistent accuracy, environmental compensation, status testing, and monitoring of sensor dirt accumulation. These housings digitally communicate their analog sensor information to the fire alarm control panel using either IDNet or MAPNET II two-wire communications.

**Relay Model.** Model 4098-9751 provides a relay that can be programmed to track the local sensor's operation or can be independently controlled by the fire alarm control panel to perform fire response actions such as fan shutdown and damper control.

## In-Duct Sensor Selection Chart

Model	Description	Compatibility
4098-9750	In-Duct Sensor Housing with beige mounting box, without relay	4007ES, 4008, 4010, 4010ES, 4020, 4100, 4100ES, 4100U, and 4120; and 2120 CDT configured for MAPNET II TrueAlarm communications
4098-9751	(requires 4098-9714 sensor) with relay	Same as above except relay operation is not compatible with 2120 CDT
4098-9714	Photoelectric Sensor Head	Ordered separately, <b>required</b> for 4098-9750 or 4098-9751

**In-Duct Sensor Options**, ordered separately as required, compatible with both 4098-9750 and 4098-9751

4098-9819	Adapter for 6" (152 mm) round duct, beige
4098-9824	Adapter for 8" (203 mm) round duct, beige
4098-9852	Adapter for 10" (254 mm) round duct, beige
4098-9853	Adapter for 12" (305 mm) round duct, beige
2098-9806	Remote Test Station mounted on single gang stainless steel plate
2098-9808	Remote LED Alarm Indicator mounted on single gang stainless steel plate

## Rectangular Duct Mounting Reference

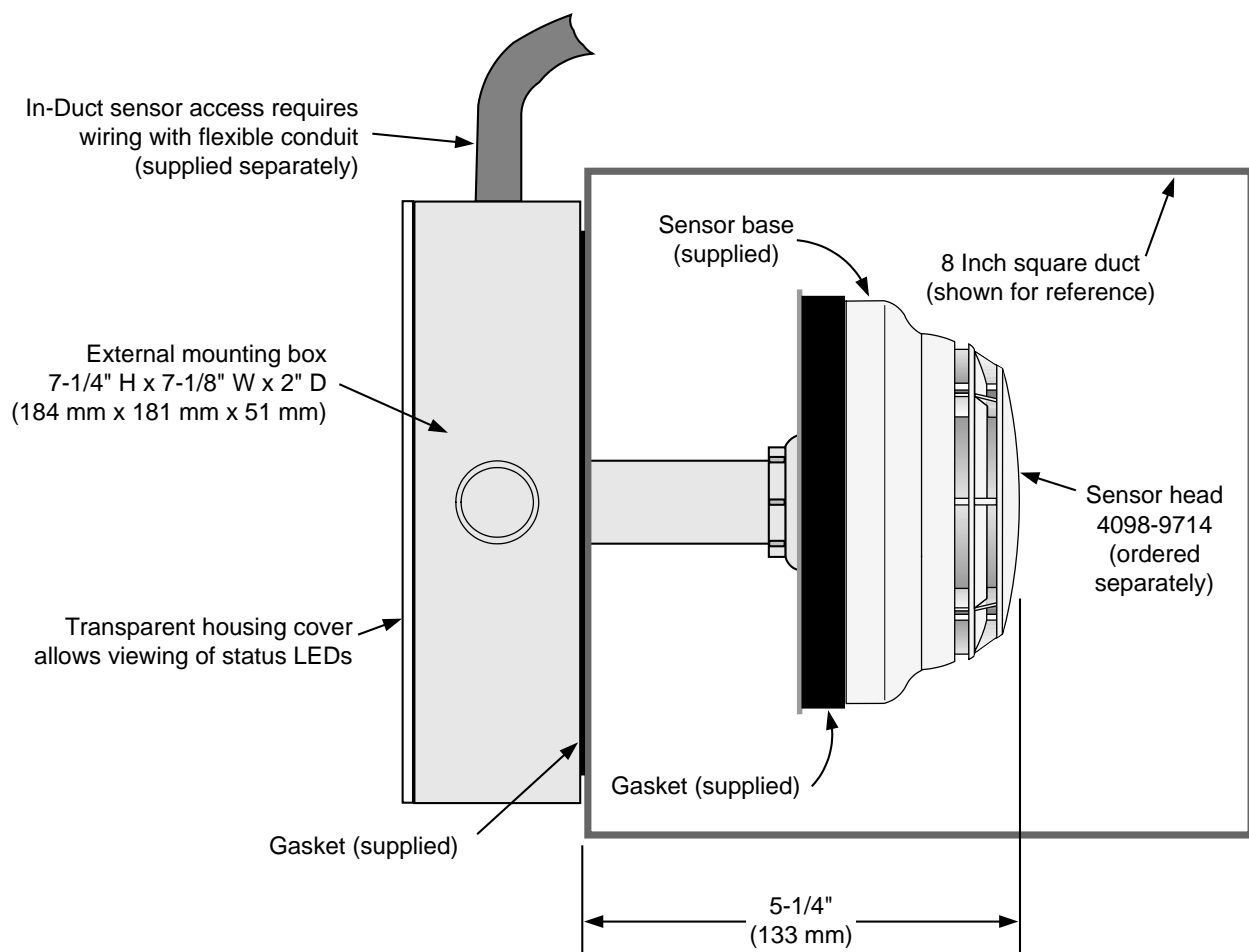

### Mounting Notes for both Square and Round Duct Applications:

1. Reference drawings are shown mounted to the side of the duct. Where appropriate, top mounting may be acceptable. Contact your local Simplex product supplier for assistance.
2. The 4098-9750 and 4098-9751 In-Duct assemblies include sensor base assembly, mounting box and cover, and mounting gaskets. The 4098-9714 sensor head is ordered separately.
3. Templates are supplied for duct cutout size and location. Refer to installation instructions 574-711 for additional information.
4. Adapters for 6", 8", 10", or 12" round duct applications are ordered separately.

## Round Duct Mounting Reference

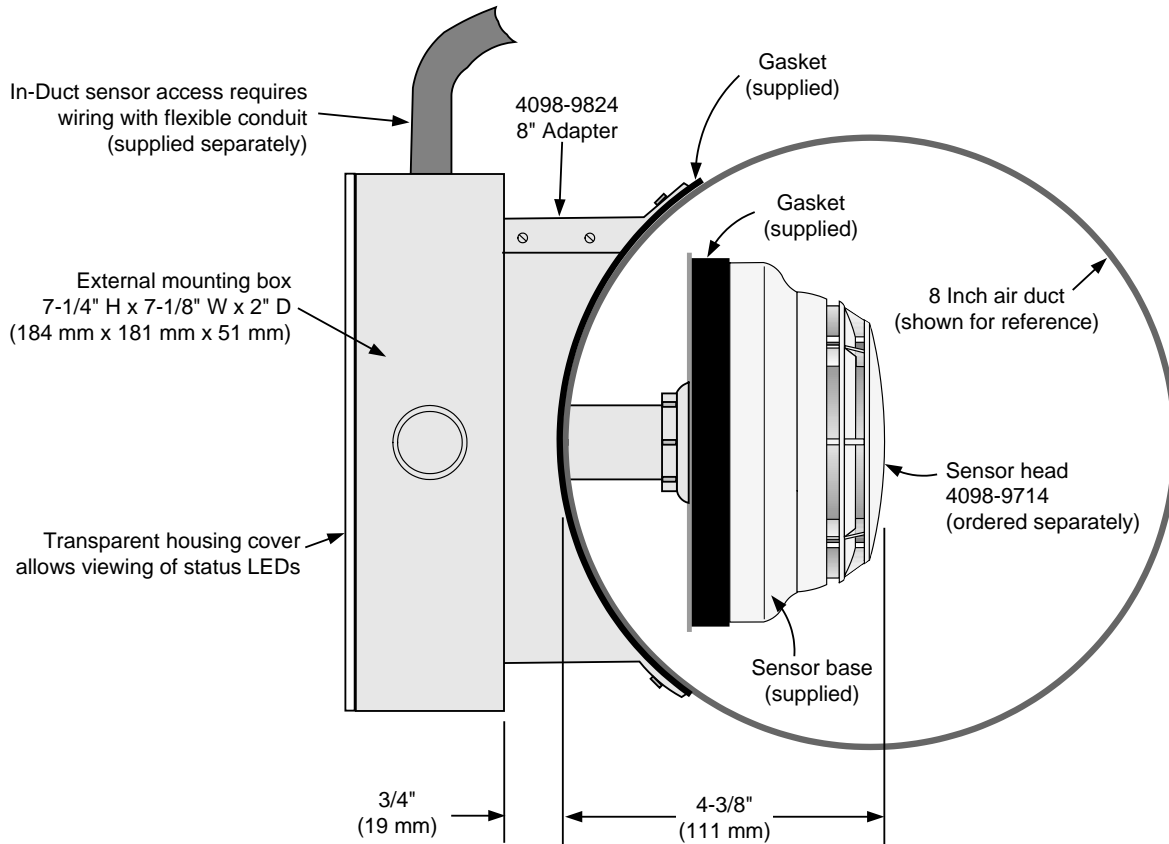

## Remote Indicator Options

**2098-9806, Remote Test Station** (below), provides a remote red LED status indicator and a remote test key mounted on a single gang stainless steel plate. Turning the test switch to "TEST" will initiate an alarm and allow the resulting system responses to be verified.

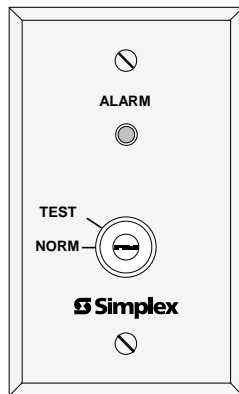

2098-9806 Remote Test Station

**2098-9808, Remote LED Alarm Indicator** (below), provides a remote Red LED status indicator mounted on a single gang stainless steel plate.

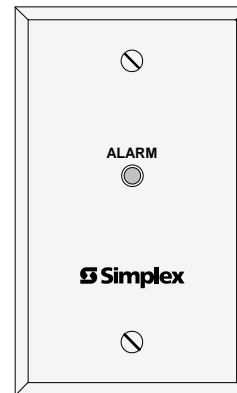

2098-9808 Remote LED Alarm Indicator

**Remote Indicator Mounting.** Both the 2098-9806 and 2098-9808 Remote status indicators mount in standard single gang boxes, 2" W x 3" H (51 mm x 76 mm) with a minimum depth of 2", supplied separately.

## Location Reference

### Duct Sensor Location Considerations:

1. Proper duct smoke detection location must ensure adequate airflow within the duct housing.
2. Ensure accessibility for test and service.
3. Proper Locations: downstream side of filters to detect fires in the filters; in return ducts, ahead of mixing areas; upstream of air humidifier and cooling coil.
4. Other locations may be required for proper duct smoke detection depending on duct access, system design, and duct airflow testing. Contact your local Simplex product supplier for assistance.

### Locations to Avoid:

1. Where dampers closed for comfort control would interfere with airflow.
2. Next to outside air inlets (unless the intent is to monitor smoke entry from that area).
3. In return air damper branch ducts and mixing areas where airflow may be restricted.

**Additional Information.** Refer to NFPA 90A, *Standard for the Installation of Air Conditioning and Ventilating Systems*; NFPA 72, the *National Fire Alarm and Signaling Code*; and the *NEMA Guide for Proper Use of Smoke Detectors in Duct Applications*, and Installation Instructions 574-711.

## In-Duct Sensor Location Reference

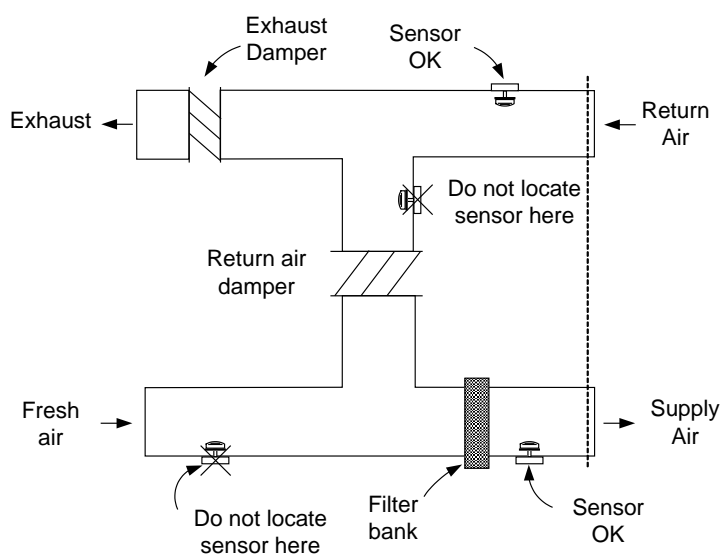

## Specifications

UL Listed Air Velocity Range	0-4000 ft/min (0-1220 m/min) with a minimum sensor sensitivity of 3.0% per ft 0-2000 ft/min (0-610 m/min) with a minimum sensor sensitivity of 3.7% per ft	<b>NOTE:</b> See application discussion on page 1.
Data Communications	IDNet or MAPNET II format, auto-selected, 1 address per housing	
Remote LED Current	0.6 mA, no impact to alarm current	
UL Listed Temperature Range	32° to 100° F (0° to 38° C)	
Operating Temperature Range	15° to 122° F (-9° to 50° C)	
Humidity Range	10% to 90% RH from 32° F to 122° F (0° C to +50° C)	
Wiring Connections	Terminal blocks for wire size 18 to 14 AWG (0.82 mm <sup>2</sup> to 2.08 mm <sup>2</sup> )	
Dimensions	Refer to round and square duct mounting diagrams	
<b>Relay Power (4098-9751 only)</b>		
Voltage	18 to 32 VDC	
Standby Current	240 μA @ 24 VDC	
Alarm Current	30 mA @ 24 VDC	
Power Limited Contact Rating	Single form "C", 1 A @ 28 VDC (for suppressed loads)	
Non-Power Limited Contact Rating	Single form "C", 1/2 A @ 120 VAC, resistive (for suppressed loads)	

TYCO, SIMPLEX, and the product names listed in this material are marks and/or registered marks. Unauthorized use is strictly prohibited. NFPA 72 and National Fire Alarm and Signaling Code are trademarks of the National Fire Protection Association (NFPA).