

B110LP Plug-In Conventional Low Profile Detector Base

Introduction	Page	3
• <i>General Description</i>		4
Installation Procedures		5
• <i>General Information</i>		5
• <i>Mounting</i>		5
• <i>Wiring Installation Guidelines</i>		7
• <i>Tamper-Proof Feature</i>		10
• <i>Limitations</i>		11

Introduction

This document contains important information about installing and operating B110LP plug-in detector bases. These conventional detectors are manufactured by System Sensor for use with Johnson Controls systems. If you install this base for someone else to use, you must leave a copy of this document with the user.

These instructions provide information regarding mounting, wiring, and installation. Follow only those instructions that apply to the model you are installing.

Before you install any B110LP plug-in detector bases, read and be familiar with:

- the system's control panel installation manual
- the requirements of the authority having jurisdiction
- National Fire Protection Association (NFPA) Standards 72-National Fire Alarm Code
- System Sensor *Guide for Proper Use of System Smoke Detectors Technical Bulletin* in the *Fire Initiating Devices and Notification Appliances Technical Manual (FAN 408)* that provides detailed information on detector spacing, placement, zoning, wiring, and special applications
- or, for non-United States installations, applicable codes and standards specific to the country and locality of installation

Failure to follow these directions may result in failure of this device to report an alarm or trouble condition or respond properly to an alarm condition. Johnson Controls is not responsible for devices that have been improperly installed, tested, or maintained by others.

**General
Description**

The B110LP 2-wire base is equipped with screw terminals for the connection of power, ground, and an optional remote annunciator.

Table 1: Detector Head Models and Accessories Used with the B110LP Detector Base

Model	Description
1151	Ionization detector head
2151	Photoelectronic detector head
RA400Z	Remote annunciator for 2- or 4- wire systems, 3-32V. Fits standard, single gang box.
XR2	Detector removal tool
XP4	Extension pole for XR2. Three 5 foot sections.

Table 2: Specifications Summary

Base Diameter	6.2 in. (157 mm)
Base Height Front of Backbox to Front of Detector	0.95 in. (24 mm)
Weight	0.3 lb (136 g)
Mounting 4 in. Square Box with or without Plaster Ring 3-1/2 inch Octagon Box	Minimum depth is 1.5 in. Minimum depth is 1.5 in.
Operating Temperature Range	32 to 120°F (0 to 49°C)
Operating Humidity Range	10 to 93% Relative Humidity Non-condensing

Installation Procedures

General Information

This section contains installation information for the B110LP plug-in detector base. Instructions are given for mounting the base, and basic installation information is provided.



CAUTION: Equipment hazard. Do not use in potentially explosive atmospheres. Do not leave unused wires exposed.

Mounting

The detector base mounts directly to 3-1/2 inch (88.9 mm) and 4 inch (101.6 mm) octagon boxes and 4 inch square boxes, with or without plaster rings.

To mount the base:

1. Remove the decorative ring by rotating it in either direction to unhook the snaps before separating the ring from the base.
2. Use the screws supplied with the junction box to attach the base to the box through the appropriate slots in the base (Figure 1).
3. Position the decorative ring around the base and rotate it in either direction until the ring snaps into place.

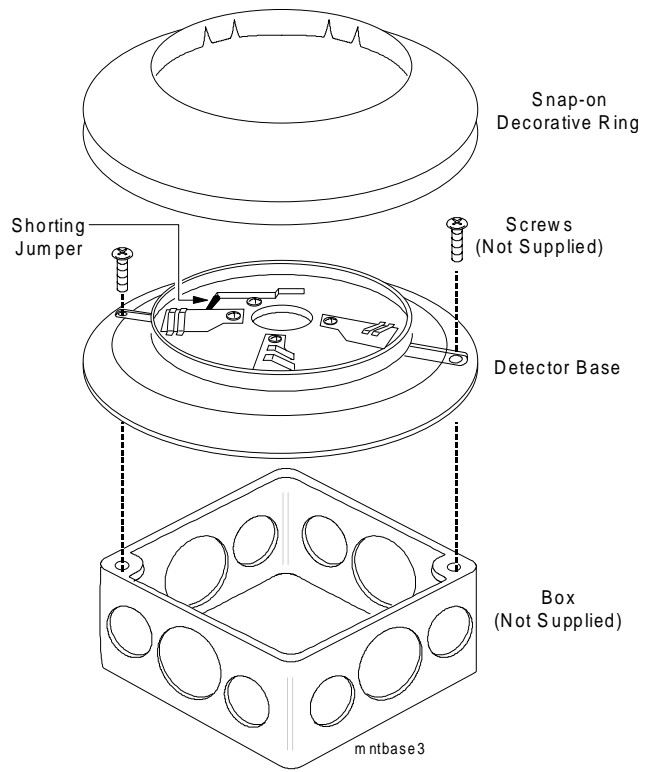

Figure 1: Mounting Detector to Box

**Wiring
Installation
Guidelines**

All wiring must be installed in compliance with the National Electrical Code (NEC), all applicable local codes, and any special requirements of the authority having jurisdiction, using the proper wire size. The conductors used to connect smoke detectors to control panels and accessory devices should be color-coded to reduce the likelihood of wiring errors. Improper connections can prevent a system from responding properly in the event of a fire.

For Initiating Device Circuit (IDC) wiring (the wiring between interconnected detectors and the fire alarm control panel), it is recommended that the wire be no smaller than No. 18 American Wire Gauge (AWG) (1.0 square mm). Wire sizes up to No. 14 AWG (2.1 square mm) for Terminals 8-14 and No. 12 AWG (3.3 square mm) for Terminals 1-5 may be used with the base. For best system performance, the IDC wires should be a twisted pair and installed in a separate grounded conduit to protect the IDC from other types of circuits in the system.

Smoke detectors and alarm system control panels have specifications for the maximum allowable IDC resistance and supervision current. Consult the control panel manufacturer's specifications for the total IDC resistance and supervisory current allowed.

The IDC zone wiring of the detector base should be checked before the detector heads are installed in them. To make this possible, this base contains a special spring-type shorting jumper. After a detector base is properly wired and mounted on an electrical box, make sure that the jumper spring is in contact with the base of Terminal 3. This temporary connection shorts the negative-in and negative-out leads and permits the wiring of the IDC to be checked for continuity.

Once all the detector bases have been wired and mounted and the IDC, power, and optional releasing device control wiring has been checked, the detector heads may be installed in the bases. The shorting spring in the base will disengage when the detector head is turned into place.

Note: Terminals 2, 3, and 5 do **not** use looped wire under terminals.
Break wire run to provide system supervision of connections.

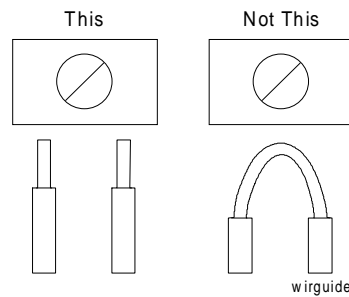

Figure 2: Electrical Connections

To make wire connections:

1. Strip insulation from the end of the wire.
2. Slide the bare end of the wire under the clamping plate.
3. Tighten the clamping plate screw.
4. Use the strip gauge molded into the base for ease of wiring to terminals.

The smoke detectors and mounting bases are marked with a compatibility identifier located as the last digit of a five digit code stamped on the back of the product. Connect detectors/mounting bases only to compatible control units as indicated in the *Device Compatibility Technical Bulletin* in the *Fire Management Accessories Manual (FAN 445)*.

The IDC zone wiring of the detector base should be checked before the detector heads are installed in them. To make this possible, this base contains a special spring-type shorting jumper. After a detector base is properly wired and mounted on an electrical box, make sure that the jumper spring is in contact with the base of Terminal 3. This temporary connection shorts the negative-in and negative-out leads and permits the wiring of the IDC to be checked for continuity.

Once all the detector bases have been wired and mounted and the IDC wiring has been checked, the detector heads may be installed in the bases. The shorting spring in the base will disengage when the detector head is turned into place.

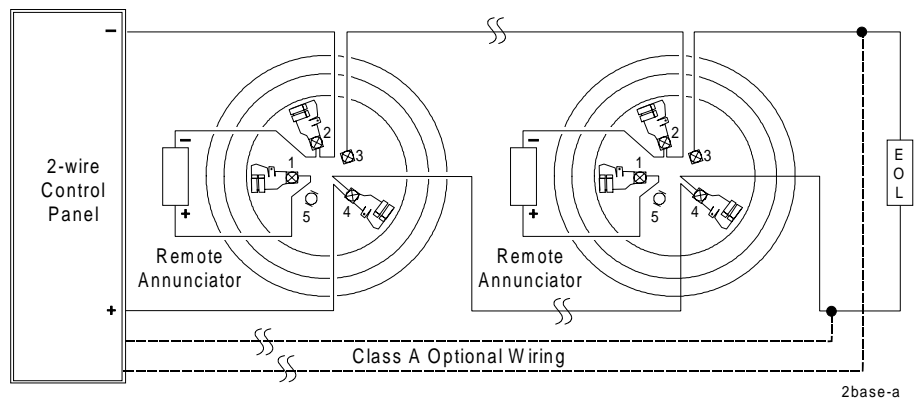

Figure 3: Wiring Diagram for a Typical 2-Wire Detector System

Tamper-Proof Feature

Note: Do not use the tamper-proof capability if the XR2 removal tool will be used to remove detectors from the base.

This detector base can be made tamper-proof so that the detector cannot be detached without the use of a tool.

To make the base tamper-proof before installing the detector:

1. Break off the smaller tab at the scribed line on the tamper-proof tab on the detector mounting bracket (Figure 4).

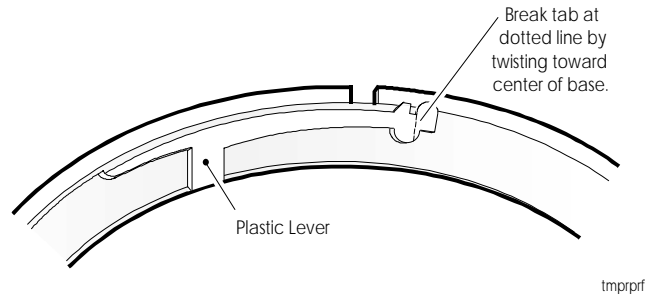

Figure 4: Enabling the Tamper-Proof Feature

To remove the detector from the base after it has been made tamper-proof:

1. Remove the decorative ring by rotating it in either direction and pulling it away from the base.
2. Insert a small screwdriver into the notch (Figure 5).
3. Press the plastic lever toward the mounting surface before rotating the detector counterclockwise for removal.

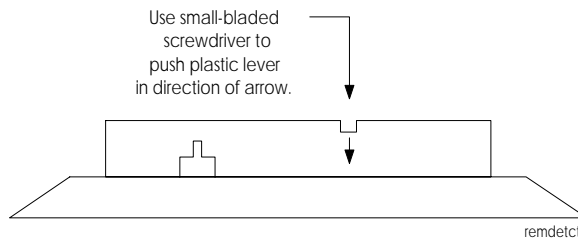

Figure 5: Removing the Detector Head from the Base

The tamper-proof feature may be defeated by breaking and removing the plastic lever from the base. However, this prevents using the feature again.

Limitations

This smoke detector used with this base is designed to activate and initiate emergency action, but will do so only when used in conjunction with other equipment. This detector is designed for installation in accordance with National Fire Protection Association (NFPA) Standards 71 and 72.

- Smoke detectors cannot work without power. Alternating Current (AC) or Direct Current (DC) powered smoke detectors will not work if the power supply is cut off for any reason.
- Smoke detectors will not sense fires which start where smoke does not reach the detectors. Smoke from fires in chimneys, in walls, on roofs, or on the other side of closed doors may not reach the smoke detector and alarm it.
- A detector may not detect a fire developing on another level of a building. For this reason, detectors should be located on every level of a building.
- Smoke detectors have sensing limitations. Ionization detectors offer a broad range fire-sensing capability, but they are better at detecting fast, flaming fires than slow, smoldering fires. Photoelectronic detectors sense smoldering fires better than flaming fires. Because fires develop in different ways, and are often unpredictable in their growth, neither type of detector is always best, and a given detector may not always provide warning of a fire. In general, detectors cannot be expected to provide warnings for fires resulting from inadequate fire protection practices, violent explosions, escaping gas, improper storage of flammable liquids like cleaning solvents, other safety hazards, or arson.

Smoke detectors compatible with this base are UL Listed to operate in specific maximum air velocities. Air velocity, along with other factors, may affect detector sensitivity. To find out the air velocities of specific detectors, see the appropriate technical bulletin. For more information, see the 1993 NFPA-72-*National Fire Alarm Code, Appendix B*.

- Test your smoke detector system per NFPA 72-*National Fire Alarm Code* or codes and standards specific to the country of installation, at least semiannually. Clean and take care of your smoke detectors regularly. Taking care of the fire detection system you have installed will measurably reduce your product liability risks.

Notes



Controls Group
507 E. Michigan Street
P.O. Box 423
Milwaukee, WI 53201

FAN 408
Fire Initiating Devices and Notification Appliances Technical Manual
Printed in U.S.A.